

OMEGA AIR
more than air





OMEGA AIR d.o.o. Ljubljana
Cesta Dolomitskega odreda 10
SI-1000 Ljubljana, Slovenia
www.omega-air.si

GPS: 46°2'27.13" 14°27'59.46"

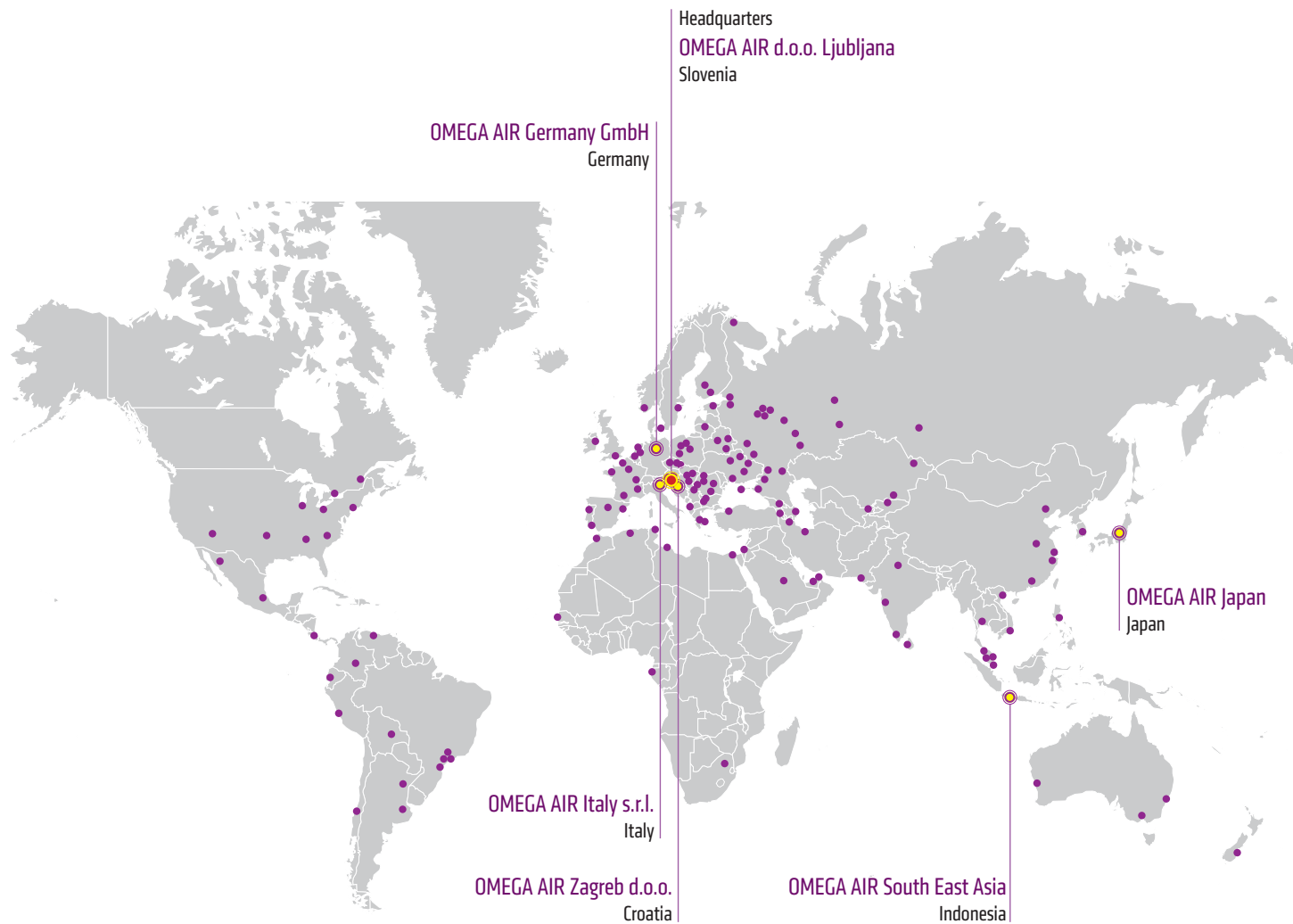



OMEGA AIR d.o.o. Ljubljana HEADQUARTERS

Ljubljana, Slovenia

Head office, Production halls, Sales office, R & D Area: 6.600 m²



OMEGA AIR Logatec

Logatec, Slovenia

Compressors and technique dept., Service centre, Welding department, Dryers production

- Land: 80.000 m² - Facilities: 4.100 m²



OMEGA AIR Logatec

Logatec, Slovenia

Main warehouse Area: 4.000 m²

OMEGA AIR d.o.o. Ljubljana



Air and Gas treatment

A complete system for every application

INDEX

- 4 Air and gas filtration
- 6 Compressed air and gas filtration
- 18 Condensate management
- 22 Drying
- 36 Gas generators
- 40 Gas dryers
- 44 Gas purifiers
- 46 Industrial water chillers
- 50 Pressure vessels
- 54 Measuring equipment
- 58 Additional program
- 60 Industrial engineering
- 62 SKID and BOX units
- 66 Projects
- 68 AirSys
- 70 Alternative filter elements



SYSTEM MONITORING

Monitoring of system parameters

- pressure
- temperature
- power consumption
- capacity
- dew point
- purity
- data logging

Benefits

- reduced operating costs
- energy savings
- control of individual system branches
- optimized operation
- history & statistics
- graphical and statistical evaluation
- analysis and comprehensive reports

COMPRESSOR

Stable compressed air

- wide pressure ranges
- energy efficient
- contemporary machines
- wide capacity ranges
- stable operation
- designed for continuous operation

Benefits

- exceptional compactness
- high ecological sustainability
- low noise level
- easy maintenance
- low operating costs
- longer product life cycle

HEAT RECOVERY UNIT

Reuse of waste heat

- 90% of energy for air compression is transferred into heat
- exploitation of up to 70% of the compressor energy
- improved energy efficiency of the system

Benefits

- simple upgrading
- inexpensive upgrading
- energy efficient system
- profitable system
- easy maintenance
- low operating costs
- compact design
- easy installation without additional control on the compressor
- upgrade regardless of compressor brand

AFTERCOOLER

Cooling

- reduces the compressed air temperature to 10 °C above ambient temperature
- reduces the water vapour dew point
- improved energy efficiency of the system

Benefits

- high efficiency axial fan
- ensures the maximum performance and protection of all equipment
- possibility to install the unit vertically or horizontally

COMPRESSED AIR RECEIVER

Storage

- buffer effect
- eliminates pulsations from the discharge line
- decreases wear and tear on the compression module, control system and motor
- reducing excessive compressor cycling
- help to reduce dew point and temperature spikes that follow regeneration
- separates moisture oil and solid particles provide extra storage for compensating surges in compressed air usage

Benefits

- reduces energy costs associated with excessive starting of the compressor motor

FILTRATION SYSTEM

Air quality

- pre-filters 25 to 3 µm
- super fine filters down to 0,01 µm
- activated carbon filters
- drying filters
- sterile filters

Pressure ranges

- low, medium and high pressure applications
- up to 420 bar

Media

- Air
- Nitrogen
- Oxygen
- Methane
- CO₂
- Argon
- Helium
- Hydrogen
- etc...

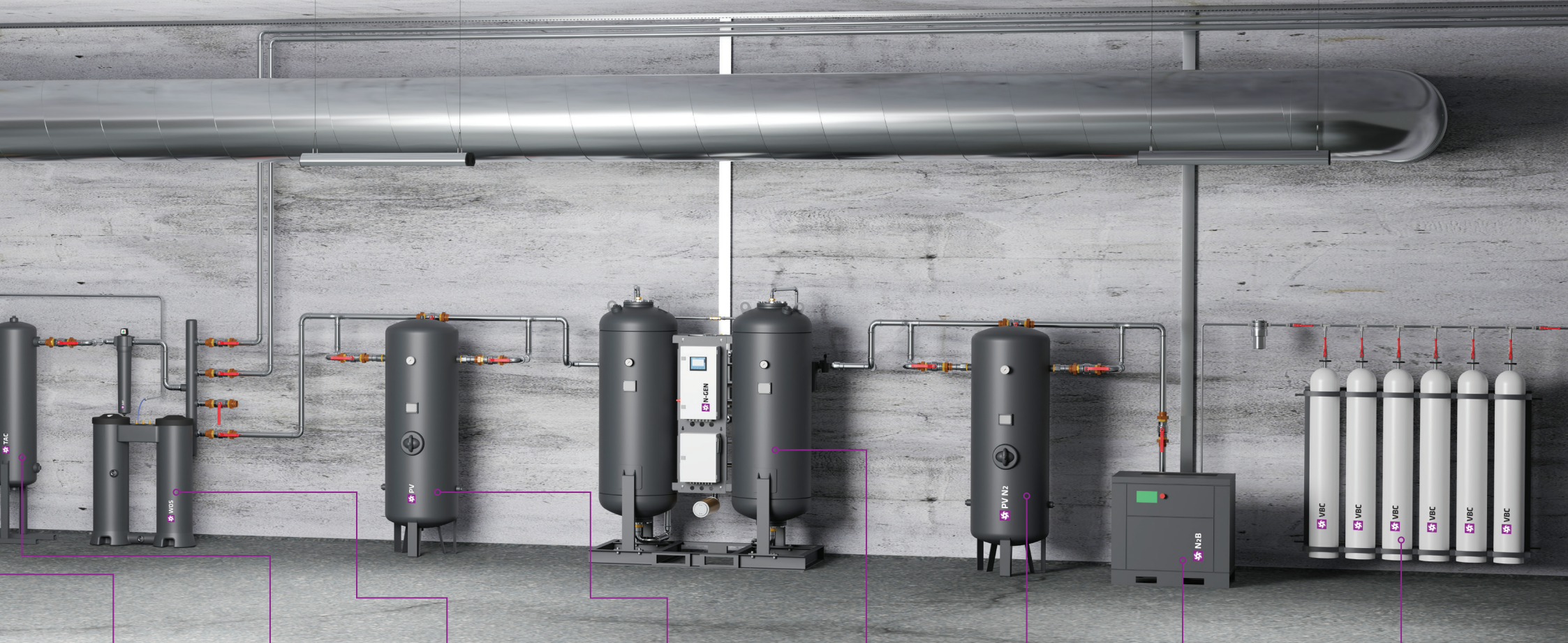

AIR DRYING

Dryer types

- refrigeration
- adsorption
- membrane

Dew points

- +15 to -70°C

Pressure ranges

- low, medium and high pressure applications
- up to 420 bar

ACTIVATED CARBON TOWERS

Air purifiers

- separating oil vapours and other hydrocarbons from compressed air
- based on adsorption process
- large adsorption surface area

Benefits

- high quality compressed air without oil presence
- safety of end product

CONDENSATE TREATMENT

Water-oil separators

- just 1 litre of used oil can contaminate 1 million litres of fresh water
- one of the most effective and economical separating solutions
- multi-stage separation process using oleophilic filters and activated carbon

Benefits

- ensures exceptional performance
- trouble free operation
- no complex sizing required
- simple to install
- works with any type of cond. drain
- can handle and separate any type of oil
- oil residue value is less than 10 ppm
- easy maintaining
- no condensate settling tank is required (no bacteria build-up)
- unique, cartridge-like solutions for lower flows
- test valve and test set included for sampling purposes

AIR BUFFER

Air receiver

- accumulates purified compressed air
- reduces peak consumption

Benefits

- storage: constant supply of purified air
- no production errors
- constant compressed air quality

GAS GENERATORS

N₂ and O₂ generators

- separating the gas from the other gases in the compressed air
- pressure swing adsorption (PSA)
- membrane separation

Benefits

- stable reliable supply of generated gas
- gas produced directly at the site of use
- constant compressed gas quality
- the manufacturing company is independent from suppliers of cylinders or liquefied gas

GAS BUFFER

Gas receiver

- accumulates treated compressed gas
- reduces peak consumption

Benefits

- reliable supply of prepared gas
- no production errors
- constant compressed gas quality

PRESSURE BOOSTER

Gas pressure booster

- builds up gas pressure

Benefits

- on-site production
- independence from suppliers of cylinders or liquefied gas

FINAL GAS STORAGE

Gas cylinders

- storage of gases at high pressures
- safe storage

Benefits

- easy transportation of compressed gases
- assures sufficient gas supply during peak consumption.
- allows installation of smaller gas generator & compressor

Compressed Air and Gas Filtration

Basics



Compressed air and gas filters are used to remove contaminants such as dirt, oil, water, and other particulates from compressed air or gas systems. They typically consist of a housing or vessel that contains a filter element or cartridge. The filter element is designed to trap contaminants as the compressed air or gas flows through it. Filters can be classified based on their filtration efficiency, filtration rating, and filtration media. It is important to select the correct filter for the specific application, as well as to maintain and replace filters on a regular basis to ensure optimal system performance and efficiency.

PRESSURE

Low	16 bar
Medium	50 bar
High	420 bar

FILTRATION

Pre-filters	25 to 3 µm
Super fine filters	down to 0,01 µm
Sterile filters	

MEDIA

GAS	<ul style="list-style-type: none"> - Air - Nitrogen - Oxygen - Methane - Biogas - CO₂ - Argon - Helium - Hydrogen
------------	---

COMPRESSED AIR AND GAS FILTERS

AAF	Aluminium compressed air filters	16 bar	10 - 2.760 Nm ³ /h
BF	Welded carbon steel compressed air filters	16 bar	1.680 - 31.400 Nm ³ /h
CS/CS SS	Welded condensate separators	16/13 bar	840 - 14.280 Nm ³ /h
SFH/SFH SS	Welded condensate separators	16/13 bar	1.760 - 12.550 Nm ³ /h
AAFs	Silicone free compressed air filters	16 bar	10 - 2.760 Nm ³ /h
AAF HT	Aluminium high temperature compressed air filters	10 (13)bar	10 - 2.760 Nm ³ /h
AAF O₂	Aluminium compressed gas filters for Oxygen	16 bar	10 - 2.760 Nm ³ /h
P-VAC	Vacuum pump protection filters	20-2.000 mbar (abs)	1,25 - 345 Nm ³ /h
M-VAC	Medical vacuum filters	20-2.000 mbar (abs)	1,25 - 345 Nm ³ /h
BF HP	High pressure welded carbon steel compressed air filters	25 bar	1.680 - 31.400 Nm ³ /h
SFH HP	Welded high pressure condensate separators	25 bar	1.760 - 12.550 Nm ³ /h
HF	Cast aluminium high pressure compressed air filters	50 bar	71 - 2.760 Nm ³ /h
HF O₂	Cast aluminium high pressure filters for Oxygen	50 bar	71 - 2.760 Nm ³ /h
CHP	Carbon steel high pressure compressed air filters	100, 250, 420 bar	40 - 715 Nm ³ /h
IHP	Stainless steel high pressure compressed air filters	100, 250, 420 bar	40 - 715 Nm ³ /h
WFIT	Welded stainless steel comp. air filters - threaded connections	14/25 bar	75 - 3.600 Nm ³ /h
WFIW	Welded stainless steel comp. air filters - welding end connections	14/25 bar	75 - 3.600 Nm ³ /h
WFIF	Welded stainless steel comp. air filters - flanged connections	10/14 bar	150 - 21.120 Nm ³ /h
WHFIT	High pressure stainless steel process compressed air filters	50 bar	150 - 2.400 Nm ³ /h
PF	Stainless steel process compressed air filters	14 bar	75 - 21.120 Nm ³ /h
SPF	Stainless steel sterile compressed air filters	14 bar	75 - 3.600 Nm ³ /h
SF	Stainless steel sterile compressed air filters	10 bar	75 - 21.120 Nm ³ /h
HPF	High pressure stainless steel process filters	50 bar	150 - 2.400 l/min
AV	Stainless steel air venting filters		9 - 310 Nm ³ /h
MSS	Mobile steam sterilizer	1 to 3,6 bar	-

Airborne particles, water vapour, microbes, and chemical gases enter compressors. After compression has taken place these contaminants become concentrated and more destructive.

Compressed air and gas quality is essential to all modern production facilities. Compressed air filters, often referred to as line filters, are used to remove these contaminants from compressed air. Clean and dry air protects the compressed air system, reduces maintenance costs and increases finished product quality.

Types of filters vary depending on the application, the pressure level and type of contaminants.

Industrial filters

Industrial filters are used in typical industrial low pressure applications. They are typically made of cast aluminium for lower air flows, and of carbon steel for higher flows. They all have anticorrosion protection.

High pressure filters

Demanding technical construction calculations according to PED and ASME ensure the safe operation of the filters even at high pressures.

Sterile filters

The rugged stainless steel housing allows the sterilization process in the demanding pharmaceutical, food and similar applications.

Filters for special applications

Different types of filters are available for special applications.

To select the right compressed air or gas filter for a specific application, the following factors should be considered:

Contaminant type and size

Identify the type of contaminants that are present in the compressed air or gas system and their size. This will help determine the appropriate filtration media, filtration rating, and filtration efficiency needed to remove these contaminants.

Flow rate

Determine the required flow rate for the compressed air or gas system to ensure that the filter is capable of handling the required volume.

Pressure and temperature

Identify the operating pressure and temperature of the compressed air or gas system. This will help determine the appropriate filter housing material, as well as the filter element material.

Application

Consider the specific application of the compressed air or gas system, as this may require additional features such as coalescing filters for removing oil or activated carbon filters for removing odors.

Maintenance

Determine the maintenance requirements for the filter, including the frequency of filter replacements or cleaning.

By considering these factors, you can select the right compressed air or gas filter for your specific application. It is important to consult with a qualified professional or refer to the manufacturer's specifications to ensure proper selection and installation of the filter.

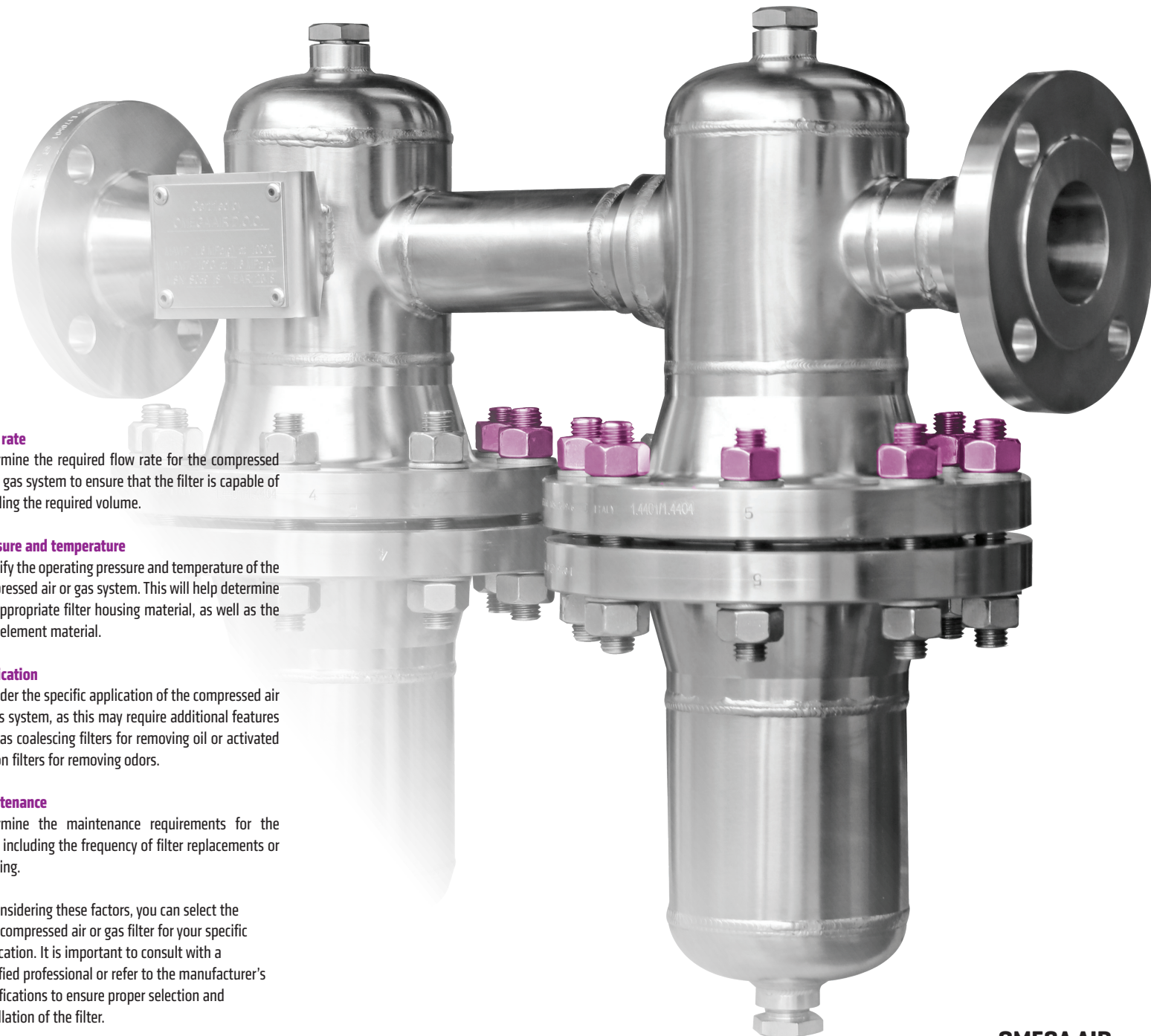

Compressed Air and Gas Filtration

Filter housings



AAF

Aluminium filters



Oper. pressure 16 bar
Capacity 10 - 2.760 Nm³/h

BF

Welded carbon steel filters



Oper. pressure 16 bar
Capacity 1.680 - 31.400 Nm³/h

CS

Welded carbon steel condensate separators



Oper. pressure 16 bar
Capacity 840 - 14.280 Nm³/h

SFH

Welded carbon steel condensate separators



Oper. pressure 16 bar
Capacity 1.760 - 12.550 Nm³/h

SFH SS

Welded stainless steel conden. separators



Oper. pressure 13 bar
Capacity 1.760 - 12.550 Nm³/h

AAFs

Aluminium silicone free filters



Oper. pressure 16 bar
Capacity 10 - 2.760 Nm³/h

AAF O₂

Aluminium filters for Oxygen



Oper. pressure 16 bar
Capacity 10 - 2.760 Nm³/h

P-VAC

Vacuum pump protection filters



Oper. pressure 20-2.000 mbar (abs)
Capacity 1,25 - 345 Nm³/h

M-VAC

Medical vacuum filters



Oper. pressure 20-2.000 mbar (abs)
Capacity 1,25 - 345 Nm³/h

<p>CS SS Welded stainless steel conden. separators</p> 	<p>SFH HP Welded high pressure cond. separators</p> 	<p>HF Cast aluminium high pressure filters</p> 	<p>HF O₂ Cast aluminium high pressure oxygen filters</p> 	<p>CHP Carbon steel high pressure filters</p> 	<p>IHP Stainless steel high pressure filters</p> 
<p>Oper. pressure 13 bar Capacity 840 - 14.280 Nm³/h</p>	<p>Oper. pressure 25 bar Capacity 1.760 - 12.550 Nm³/h</p>	<p>Oper. pressure 50 bar Capacity 71 - 2.760 Nm³/h</p>	<p>Oper. pressure 50 bar Capacity 71 - 2.760 Nm³/h</p>	<p>Oper. pressure 100, 250, 420 bar Capacity 40 - 715 Nm³/h</p>	<p>Oper. pressure 100, 250, 420 bar Capacity 40 - 715 Nm³/h</p>
<p>AAF HT Aluminium high temperature filters</p> 	<p>WFIT Welded stainless steel filters - threaded con.</p> 	<p>WFIW Welded stainless steel filters - welded con.</p> 	<p>WFIF Welded stainless steel filters - flanged conn.</p> 	<p>WHFIT High pressure stainless steel process filters</p> 	<p>PF Stainless steel process filters</p> 
<p>Oper. pressure 10/13 bar Capacity 10 - 2.760 Nm³/h</p>	<p>Oper. pressure 14/25 bar Capacity 75 - 3.600 Nm³/h</p>	<p>Oper. pressure 14/25 bar Capacity 75 - 3.600 Nm³/h</p>	<p>Oper. pressure 10/14/25 bar Capacity 150 - 21.120 Nm³/h</p>	<p>Oper. pressure 50 bar Capacity 150 - 2.400 Nm³/h</p>	<p>Oper. pressure 14 bar Capacity 75 - 21.120 Nm³/h</p>
<p>BF HP High pressure welded carbon steel filters</p> 	<p>SPF Stainless steel sterile filters</p> 	<p>SF Stainless steel sterile filters</p> 	<p>HPF High pressure stainless steel process filters</p> 	<p>AV Stainless steel air venting filters</p> 	<p>MSS Mobile steam sterilizer</p> 
<p>Oper. pressure 50 bar Capacity 1.680 - 31.400 Nm³/h</p>	<p>Oper. pressure 14 bar Capacity 75 - 3.600 Nm³/h</p>	<p>Oper. pressure 10 bar Capacity 75 - 21.120 Nm³/h</p>	<p>Oper. pressure 50 bar Capacity 150 - 2.400 Nm³/h</p>	<p>Oper. pressure Capacity 9 - 310 Nm³/h</p>	<p>Oper. pressure 1 to 3,6 bar Capacity</p>

Compressed Air and Gas Filtration

Filtration principles



Modern production companies need expensive and complex production equipment to meet the demands of the modern market. Equipment and machines which are powered by compressed air are worth nothing, if the quality of compressed air is poor. Downtime and unreliability are not acceptable.

Compressed air contamination is a real problem, which cannot be ignored. Even the most simple and basic use of compressed air requires a minimum treatment, comprising the elimination of water, oil and solids.

To guarantee maximum performance and reliability, clean, dry, reliable compressed air supply is essential to maintain efficient and cost effective production. The key factor in planning an efficient compressed air system is to know all sources and types of compressed air contaminants and the required maximum levels of certain contaminants.

Contaminants come to compressed air and gas system from different sources:

- Atmospheric air, containing water vapour, dust, oil vapours and microorganisms.
- Air compressor generates oil contaminants in liquid, aerosol and vapour phase.
- Air receivers (pressure vessels) and distribution systems generates corrosion and scales.

The degree of purification of individual contaminants must be consistent with the needs of the application and the requirements of ISO 8573-1, which prescribes compressed air quality classes.

COMPRESSED AIR QUALITY CLASSES ACCORDING TO ISO 8573-1

CLASS	SOLID PARTICLES			HUMIDITY AND LIQUID WATER		OIL	
	Maximum number of particles per cubic meter as a function of particle size, d ⁽¹⁾			Pressure dew point		Concentration of total oil ⁽¹⁾ (liquid, aerosol and vapor)	
	0,1 µm < d ≤ 0,5 µm	0,5 µm < d ≤ 1,0 µm	1,0 µm < d ≤ 5,0 µm	°C	°F	mg/m ³	ppm/w/w
0	As specified by the equipment user or supplier and more stringent than class 1						
1	≤ 20.000	≤ 400	≤ 10	≤ -70	-94	≤ 0,01	≤ 0,008
2	≤ 400.000	≤ 6.000	≤ 100	≤ -40	-40	≤ 0,1	≤ 0,08
3	Not specified	≤ 90.000	≤ 1.000	≤ -20	-4	≤ 1	≤ 0,8
4	Not specified	Not specified	≤ 10.000	≤ +3	38	≤ 5	≤ 4
5	Not specified	Not specified	≤ 100.000	≤ +7	45	Not specified	Not specified
6				≤ ±10	50		
	Mass concentration ⁽¹⁾ - C _p			LIQUID WATER CONTENT ⁽¹⁾ - C _w			
	mg/m ³			g/m ³			
6	0 < C _p ≤ 5					Not specified	Not specified
7	5 < C _p ≤ 10			C _w ≤ 0,5		Not specified	Not specified
8	Not specified			0,5 ≤ C _w ≤ 5		Not specified	Not specified
9	Not specified					Not specified	Not specified
X	C _p > 10					> 5	> 4

⁽¹⁾ At reference conditions: air temperature of 20° C, absolute air pressure of 100 kPa (1 bar), 0 relative water vapour pressure.

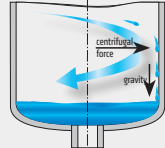
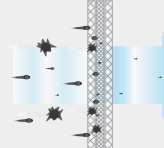
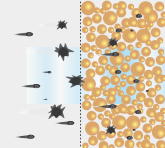
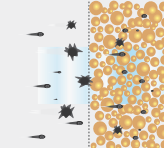
CKL grade cyclone separator	N grade prefilter 25/5 µm	I grade prefilter 20/1 µm	B grade prefilter 15 µm
			
quality class (ISO 8573-1)	quality class (ISO 8573-1)	quality class (ISO 8573-1)	quality class (ISO 8573-1)
solids, oil	solids	solids	solids
	-	-	7
water	oils	oils	oils
8	-	-	-
material	material	material	material
	- stainless steel mesh	- sintered stainless steel 1.4404	- sintered brass

Condensate separators

Cyclone condensate separators use centrifugal motion to force condensate out of compressed air. The spinning causes the condensate to gather on walls of the centrifugal separators. When the condensate gains enough mass it moves to the bottom of the separator bowl where the blind plate calms the air flow and prevents the condensate from being sucked to the outlet. Condensate is removed out of the system by the condensate drain.

General purpose filters

Pre-filter elements are designed for efficient removal of coarse solid particles and bulk liquids from compressed air. This type of filter is generally used as a pre-filter for the coalescing filter. They are required by non-lubricated and lubricated compressors.

Oil removal filters

Coalescing filter elements are used for a highly efficient removal of solid particles, oil aerosols and water from compressed air. Oil removal filters are usually made of special coalescence

material based on glass fibers. These materials enables the formation of oil drops, which are forced to the outside of the filter by air flow. When it reaches the exterior of the filter material, it is stopped in a porous foam material, which covers the filter element, and then runs down to the bottom of the filter housing. The oil is discharged by the automatic condensate drain.

Activated carbon filters

Activated carbon filters are two stage filter elements. They are required in applications, where the air is required for breathing; mixing with food, pharmaceutical products or other similar applications. Activated carbon filter elements are designed for highly efficient removal of oil, hydrocarbons, vapors and odours from compressed air. Activated carbon is an excellent adsorbent for oil vapors and a medium suitable for the purification of compressed air. It must be in fine granulated form to generate a large surface on which the adsorption can occur. It is essential that the coalescing filter element is installed as a pre-filter upstream to the activated carbon filter.

Catalyst filters

Two stage catalyst filter elements are used for a highly efficient reduction of carbon monoxide as well as some other substances from compressed breathing air. In the first stage the Hopcalite catalyst reduces the level of these substances from the air and in the second stage the depth fiber filter media intercepts all Hopcalite dust particles.

It is essential that coalescing filter element is installed as a pre-filter to the Catalyst grade filter and that relative humidity is sufficiently low.

Molecular sieve filters

A molecular sieve filters are two stage filter elements. Molecular sieve is material with pores (very small holes) of uniform size. These pores match the dimensions of small molecules, thereby preventing the adsorption of large molecules and only allowing the passage of smaller molecules.

Molecular sieve filter elements are used for separating water vapor from small flows of compressed air and therefore for air drying. In the first stage, the desiccant adsorbs water vapor

from the air and in the second stage the depth fiber filter media intercepts all dust particles. The molecular sieve filtration grade is suitable for point of use applications. It is important that inlet air is free of liquid water and oil aerosols.

Sterile filters

Sterile filters eliminate micro-organisms from compressed air and they are used and are used in processes and systems which require the highest air quality. Sterile filters are made of materials that enable high temperature steam sterilization. The sterile filter element is used for highly efficient sterile filtration of compressed air, processed air and technical gasses.

The depth filter medium made of borosilicate glass microfibers ensures highly efficient removal of submicron particles down to 0,01 µm including microorganisms (bacteria). The filter medium supported with NOMEX is rigidly held between two stainless steel cylinders and encapsulated between stainless steel end-caps. This results in exceptionally strong filter element that ensures highly efficient filtration and allows a large number of sterilization cycles.

P grade prefilter	3 µm	XR grade prefilter	1 µm	XM grade microfilter	0,1 µm	XS grade microfilter	0,01 µm	A grade activated carbon	A ² grade adsorption	H ² grade catalyst	MS ² grade molecular sieve	VSF grade sterile					
quality class (ISO 8573-1)		quality class (ISO 8573-1)		quality class (ISO 8573-1)		quality class (ISO 8573-1)		quality class (ISO 8573-1)		quality class (ISO 8573-1)		quality class (ISO 8573-1)		quality class (ISO 8573-1)			
solids	6	solids	3	solids	2	solids	1	solids	1	solids	1	solids	1	solids	1		
oils	-	oils	-	oils	2	oils	1	oils	1	oils	0/1	oils	-	oils	-		
material		material		material		material		material		material		material		material			
- acrylic fibres - cellulose		- borosilicate micro fibres		- borosilicate micro fibres		- borosilicate micro fibres		- activated carbon - borosilicate micro fibres		- activated carbon - borosilicate micro fibres		- hopcalite - borosilicate micro fibres		- molecular sieve - borosilicate micro fibres			
														- borosilicate micro fibres - Nomex™			

Compressed Air and Gas Filtration

Filter elements

FILTER ELEMENTS AND FILTER HOUSING COMPATIBILITY																			
Filter element type		CKL	N ₂₅	I	IW	B	N ₅	P	XR	XM	XS	A	A ²	H ²	MS ²	CKL	VSF	AVF	
filtration grade			25 µm	20, 1µm	20, 1µm	15 µm	5 µm	3 µm	1 µm	0,1 µm	0,01 µm	activated carbon	activated carbon	catalyst	adsorption	water separation	sterile	vent	
AAF	Aluminium compressed air filters	✓	-	-	-	✓	-	✓	✓	✓	✓	✓	✓	✓	✓	✓	-	-	
BF	Welded carbon steel compressed air filters	-	-	-	-	✓	-	✓	✓	✓	✓	✓	-	-	-	-	-	-	
CS/CS SS	Welded condensate separators	-	-	-	-	-	-	-	-	-	-	-	-	-	-	-	-	-	
SFH/SFH SS	Welded condensate separators	-	-	-	-	-	-	-	-	-	-	-	-	-	-	-	-	-	
AAFs	Silicone free compressed air filters	-	-	-	-	-	-	✓	✓	✓	✓	✓	-	-	-	-	-	-	
AAF HT	Aluminium high temperature compressed air filters	✓	✓	-	-	✓	✓	-	✓	✓	✓	-	-	-	-	✓	-	-	
AAF O₂	Aluminium compressed gas filters for Oxygen	-	-	-	-	-	-	-	✓	✓	✓	-	-	-	-	-	-	-	
P-VAC	Vacuum pump protection filters	-	-	-	-	-	-	✓	-	✓	-	-	-	-	-	-	-	-	
M-VAC	Medical vacuum filters	-	-	-	-	-	-	-	-	-	-	-	-	-	-	-	-	-	
BF HP	High pressure welded carbon steel compressed air filters	-	-	-	-	✓	-	✓	✓	✓	✓	✓	-	-	-	-	-	-	
SFH HP	Welded high pressure condensate separators	-	-	-	-	-	-	-	-	-	-	-	-	-	-	-	-	-	
HF	Cast aluminium high pressure compressed air filters	✓	-	-	-	✓	-	✓	✓	✓	✓	✓	-	-	-	-	-	-	
HF O₂	Cast aluminium high pressure filters for Oxygen	-	-	-	-	-	-	-	✓	✓	✓	-	-	-	-	-	-	-	
CHP	Carbon steel high pressure compressed air filters	✓	-	-	-	✓	-	✓	✓	✓	✓	✓	-	-	-	✓	-	-	
IHP	Stainless steel high pressure compressed air filters	✓	✓	-	-	-	✓	-	✓	✓	✓	✓	-	-	-	✓	-	-	
WFIT	Welded stainless steel comp. air filters - threaded connections	✓	✓	✓	✓	-	✓	✓	✓	✓	✓	✓	-	-	-	✓	-	-	
WFIW	Welded stainless steel comp. air filters - welding end connections	✓	✓	✓	✓	-	✓	✓	✓	✓	✓	✓	-	-	-	✓	-	-	
WFIF	Welded stainless steel comp. air filters - flanged connections	✓	✓	✓	✓	-	✓	✓	✓	✓	✓	✓	-	-	-	✓	-	-	
WHFIT	High pressure stainless steel process compressed air filters	✓	✓	✓	✓	-	✓	✓	✓	✓	✓	✓	-	-	-	✓	-	-	
PF	Stainless steel process compressed air filters	-	✓	✓	✓	-	✓	✓	✓	✓	✓	✓	-	-	-	✓	✓	-	
SPF	Stainless steel sterile compressed air filters	-	✓	✓	✓	-	✓	✓	✓	✓	✓	✓	-	-	-	✓	✓	-	
SF	Stainless steel sterile compressed air filters	-	-	-	-	-	-	-	-	-	-	-	-	-	-	-	✓	-	
HPF	High pressure stainless steel process filters	-	✓	✓	✓	-	✓	✓	✓	✓	✓	✓	-	-	-	✓	✓	-	
AV	Stainless steel air venting filters	-	-	-	-	-	-	-	-	-	-	-	-	-	-	-	-	✓	
MSS	Mobile steam sterilizer	-	-	-	-	-	-	-	-	-	-	-	-	-	-	-	-	-	

CKL
condensate separator



Construction:
- stainless steel construction
- abs plastic insert

N 25; 5 µm
prefilter



Layers:
- stainless steel expanded mesh 1.4301
- stainless steel filtration mesh
- stainless steel expanded mesh 1.4301

I 20; 1 µm
prefilter



Layers:
- sintered stainless steel 1.4404

IW 20; 1 µm
prefilter

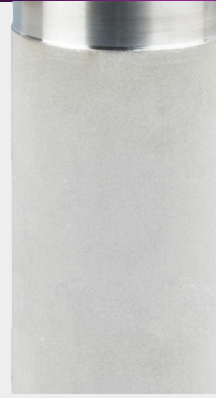

Layers:
- sintered stainless steel 1.4404

B 15 µm
prefilter



Layers:
- sintered brass

P 3 µm
prefilter



Layers:
- stainless steel expanded mesh
- nonwoven layer
- acrole fibres, cellulose
- stainless steel expanded mesh

XR 1 µm
prefilter



Layers:
- stainless steel expanded mesh
- nonwoven layer
- acrole fibres, cellulose
- stainless steel expanded mesh
- needle felt

XM 0,1 µm
general purpose filter



Layers:
- stainless steel expanded mesh
- nonwoven layer
- depth fiber filter layer (borosilicate micro fibers)
- coalescing layer (borosilicate micro fibers)
- stainless steel expanded mesh
- needle felt

XS 0,01 µm
super fine filter



Layers:
- stainless steel expanded mesh
- nonwoven layer
- depth fiber filter layer (borosilicate micro fibers)
- coalescing layer (borosilicate micro fibers)
- stainless steel expanded mesh
- needle felt

A adsorption
activated carbon



Layers:
- stainless steel expanded mesh
- nonwoven layer
- activated carbon media
- depth fiber filter layer (borosilicate micro fibers)
- stainless steel expanded mesh

A² adsorption
activated carbon



Layers:
- stainless steel expanded mesh
- activated carbon media
- nonwoven layer
- depth fiber filter layer (borosilicate micro fibers)
- stainless steel expanded mesh

H²
catalyst



Layers:
- stainless steel expanded mesh
- hopcalite
- nonwoven layer
- depth fiber filter layer (borosilicate micro fibers)
- stainless steel expanded mesh

MS²
molecular sieve



Layers:
- stainless steel expanded mesh
- molecular sieve
- nonwoven layer
- depth fiber filter layer (borosilicate micro fibers)
- stainless steel expanded mesh

VSF
sterile



Layers:
- stainless steel expanded mesh
- carrier layer
- depth fiber filter layer (borosilicate micro fibers)
- stainless steel expanded mesh
- Nomex™

Compressed Air and Gas Filtration

System pressure drop



Knowing the pressure drop level is important!

1 bar of pressure drop = 7-8%
of additional compressor energy !!!

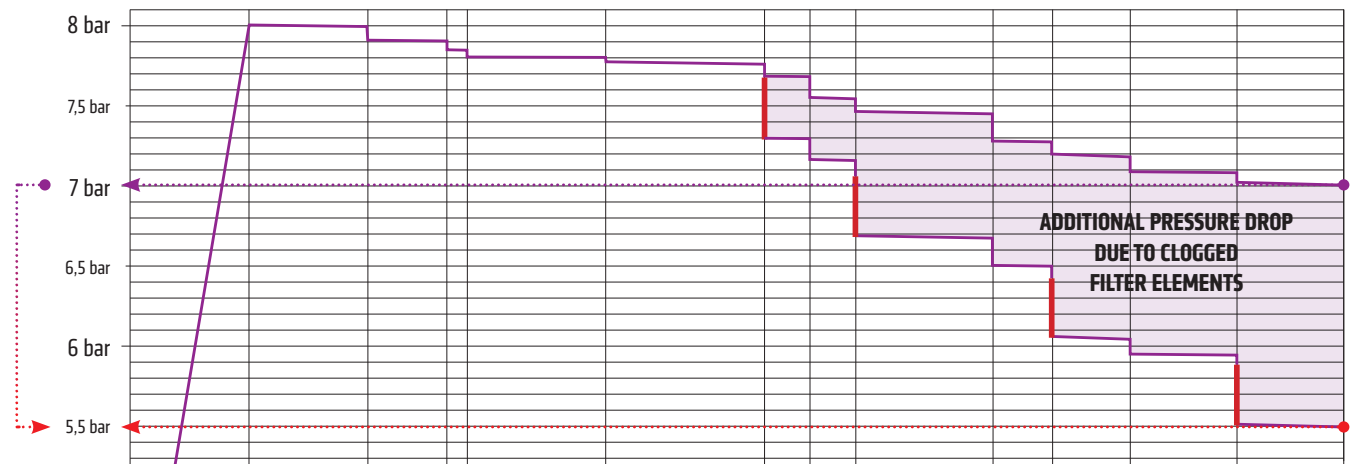

Pressure drop in compressed air system

Pressure drop is a huge problem in compressed air system. Every additional obstruction of compressed air flow requires additional power to drive the compressor.

Compressed air system pipeline has fixed pressure drop, which has already been taken into account in the phase of compressor dimensioning. This pressure drop generally can't be changed.

Filter element pressure drop is variable factor of compressed air system. Despite the fact that the filter element play a useful role in the removal of compressed air pollutants, it's saturation could be a problem since it will increase in time. The result is an increase of pressure drop, additional compressor power, which means the significantly rising of operating costs.

For this reason the pressure drop in filter element must be monitored and controlled.

Omega Air produces several types of products for this purpose. There are indicators of pressure drop with an analogue or digital display of saturation level of the filter element, some of them with output for remote monitoring.

CHANGE THE FILTER ELEMENTS REGULARLY !

The filtering efficiency of the saturated filter is much higher, since the pores of the filtering medium are narrower. However, this significantly increases the pressure drop in the system. 1 bar of pressure drop, causes the request for 7 to 8% of additional energy to drive the compressor.

Omega Air products have a very low pressure drop. For instance, when first installed in the housing, the pressure drop of the pre-filter cartridge of 3 microns is as low as 10 mbar. Control pressure drop at any time with any of our pressure drop indicators.

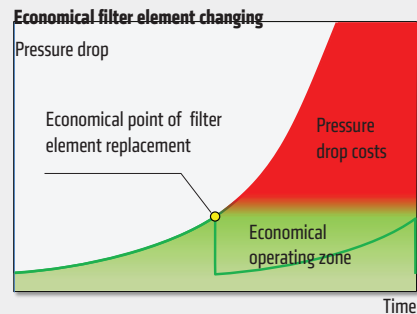

Compressed Air and Gas Filtration

Indicators

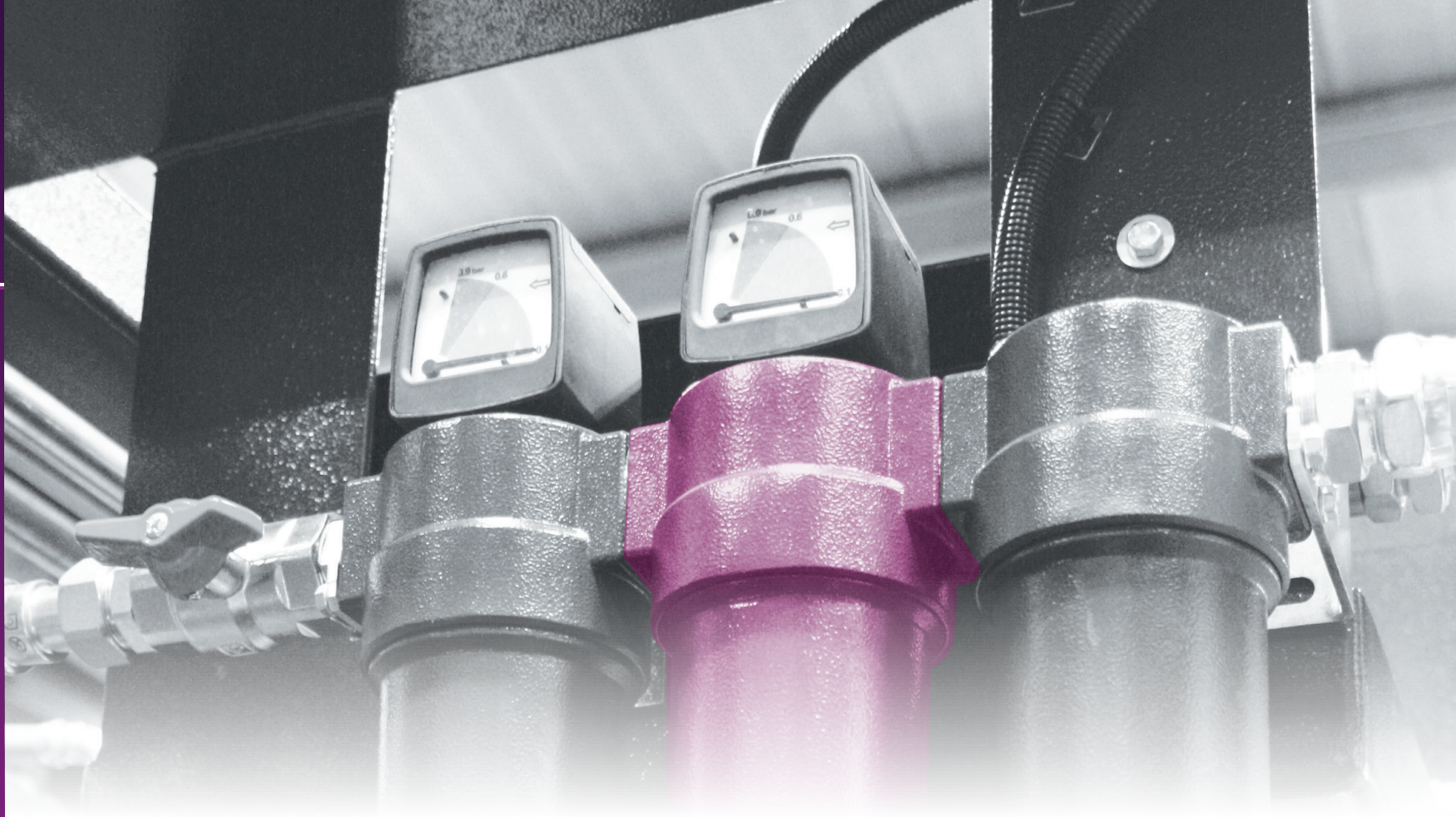

INDICATORS

PDI 16	Differential pressure indicator	16 bar
MDM 40	Differential pressure indicators	20 bar
MDA 60	Differential pressure indicators	20 bar
VPG 40	Differential pressure indicators	20-2000 mbar
EPG 60	Electronic pressure gauge	16 bar
MDH 200	Differential high pressure indicators	200 bar
MDH 420	Differential high pressure indicators	420 bar
MDHI 50	Differential high pressure stainless steel indicator	50 bar
OCI	Oil content indicator	0,68 - 16 bar
CHI	Humidity indicator	20 bar

Maintaining pressure drop is an important way to make the compressed air system energy efficient. Pressure drop is the difference between the compressor discharge pressure and pressure that comes to the actual user of the compressed air, for example, the laser cutting machine. Pressure drop is thus undesirable and is an indirect cost that results in higher electricity bill and higher production price of the end goods.

It occurs due to improper sizing of air treatment equipment and due to insufficient maintenance of the equipment. According to the rules of good practice, a properly designed system should have a pressure drop less than 10% compared to the compressor's discharge pressure, measured from the receiver tank output to the user (machine or tool).

The problem with pressure drop is even worse during times when the airflow and temperature are at highest. With higher temperatures in the summer months and increased humidity, more water comes into the compressed air system. Filters are affected by this additional moisture and when pressure drop rises compressor running costs are higher. Therefore, it is advisable to replace the filter elements at that time.

Select correct filters and separators

- When selecting filters please remember that they will gradually saturate. For your convenience we provide the information about pressure drop when the element is dry and when it is wet. Please check our product data sheets for this information.
- The pressure drop of our 3 micron cartridges marked P or /P is just 10 mbar in dry condition, making it very effective and energy saving.

Maintain filtering and drying level

- Wet conditions are undesirable for compressed air systems. Not only corrosion but also higher pressure drop appears. Thoughtful choice of drying technology further depends on the required dew point. For many applications, refrigeration dryer is enough.
- For stable quality and low cost filtration it is recommended to replace the filter element after 12 month of operation (6 months for A element) or when pressure drop exceeds 350 mbar.

PDI 16

Differential pressure indicators



Oper. pressure 16 bar

MDM 40

Differential pressure indicators



Oper. pressure 20 bar

MDA 60

Differential pressure indicators



Oper. pressure 20 bar

VPG 40

Differential pressure indicators



Oper. pressure 20-2000 mbar

EPG 60

Electronic pressure gauge



Oper. pressure 16 bar

MDH 200

Differential high pressure indicators



Oper. pressure 200 bar

MDH 420

Differential high pressure indicators



Oper. pressure 420 bar

MDHI 50

Diff. high pressure stainless steel indicators



Oper. pressure 50 bar

OCI

Oil content indicator



Oper. pressure 0,68 - 16 bar

CHI

Humidity indicator

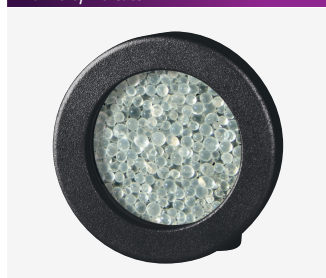

Oper. pressure 20 bar

Condensate management

Basics

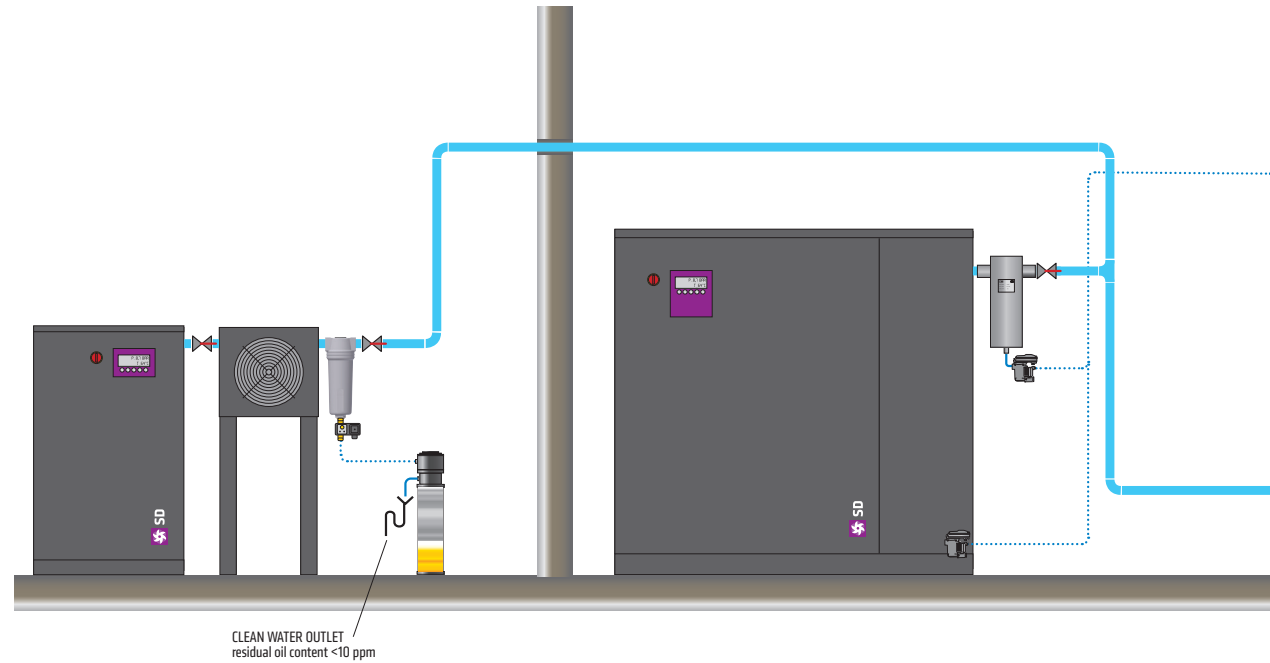
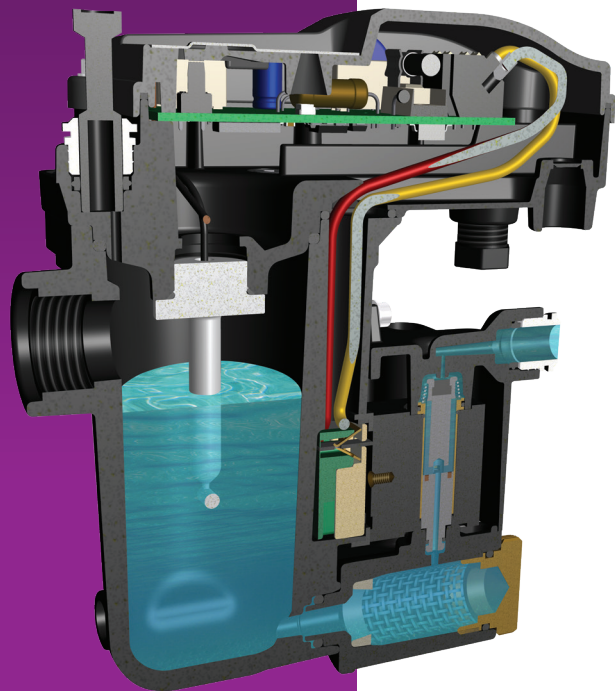

Compressing is a process, where atmospheric air, containing impurities (hydrocarbon or chemical vapours) and water moisture is drawn into compressor. Compressors mostly require oil for lubrication, sealing and cooling. At the end of compression, hot compressed air flows into an aftercooler to remove the heat of compression. During cooling, processed water and hydrocarbon vapours will condense. The air is further cooled in the piping and air dryers, where additional condensation takes place.

Condensate draining equipment is possibly the most ignored component of a compressed air system but nevertheless, the most important part. No matter how much money you wasted on high-quality equipment for compressed air (compressors, dryers, filters), compressed air quality becomes worthless, if the condensate is not discharged from the system.

Condensate in a compressed air system can cause large problems:

- An inconsistent supply of dry air will cause production problems. For example, the moisture will wash away the lubrication from air tools, and cause erratic performance, downtime and maintenance.

- The presence of water will lead to the formation of rust and scale in the air piping system. This solid contamination may cause damage to the equipment.
- Your air dryers and inline filtration products will not perform if they become overloaded with liquid contamination. Slugs of water due to drain failure can cause major problems in a desiccant dryer.
- Also, water can back up into the compressor and wreck the machinery.
- When a drain fails to eject all of the condensate collected, oil and/or water will accumulate, affecting filter efficiency, causing carry over into the system and allowing freeze-up in the winter.
- Drains stuck in the open position due to condensate debris can be a major source of wasted energy in some plants.
- The condensate transferred to the end user, can lead to irreparable consequences to the final product or process.

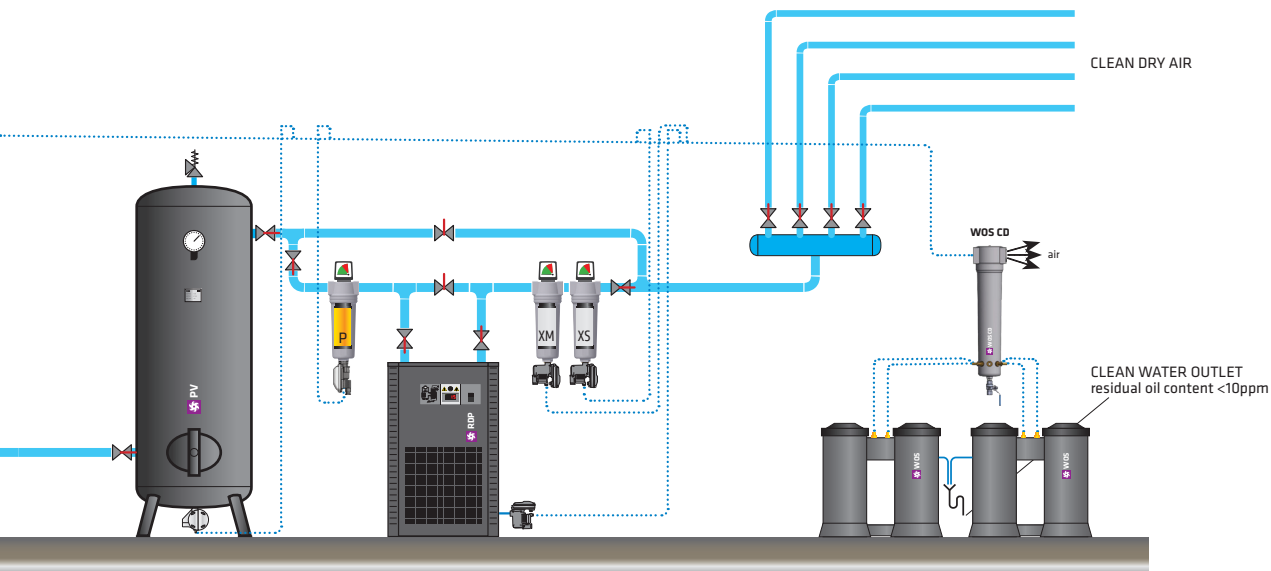

Drain valves are installed on moisture separators, coalescing filters, air receivers, air dryers and drip legs to remove this condensate from the compressed air system. The condensate should be piped from automatic drain valves to oil/water separators to remove the oil from the condensate before it is discharged into a drain. Make sure, that the drains operate properly. This is the only way to ensure that the filters and separators are successful in completing their task.

Always slope or pitch the pipe in the main air header and in the branch air lines downward in the direction of the air flow. This will allow the condensation to collect at the low points, where it can be trapped and drained from the compressed air systems. Always install the valves to the end of pipes. If possible, use materials resistant to corrosion and oxidation.

Since water moisture is a part of atmospheric air, condensate in compressed air systems can't be avoided. During the compression process, the air is heated. It cools down as it passes through hoses, valves and piping. As it approaches the ambient temperature, vapour condenses to liquid and can be removed by mechanical separation. As the air cools further, more condensate is present.

Water moisture is not the only undesirable substance. There are also other pollutants in compressed air: lubricating oil carry over from oil lubricated air compressors, atmospheric corrosive gases drawn in by the air compressor, aerosols and vapours, solid particles and rust from the piping system and pressure vessels and solid particles drawn in by the air compressor.

The first stage is to remove the major part of condensate, which contains a large amount of upper mentioned pollutants. This can be done by aftercoolers and condensate separators.

The second stage is the removal by coalescing filters, and the last stage is air drying by refrigeration or adsorption dryers.

Condensate should be then removed from the compressed air system by automatic or manual condensate drains.

Condensate is an unavoidable result of air compression. It is a chemically aggressive fluid that mainly consists of water, but also contains oil and dirt particles. Oil carryover is unavoidable if you have compressors that use oil in the compression chamber. The lubricant will mix with the condensation and create an oily water that must be properly handled to avoid violating environmental regulations.

Just one litre of used oil can contaminate up to one million litres of fresh water. That's why environmental regulations strictly prohibit the discharge of oily wastes and chemicals, including the condensate drained from a compressed air system. Compressed air condensate must therefore be treated in accordance with water resource legislation to achieve prescribed safety levels before it can be disposed of in the waste water system.

Compressor condensate must therefore be either collected and treated by special processes or treated prior to disposal to the environment. An oil/ water separator can be used here to remove the oil from the condensate. Since the condensate is approximately 95% water and 5% oil, water/oil separators have been developed to reduce or eliminate the amount of oil in the condensate.

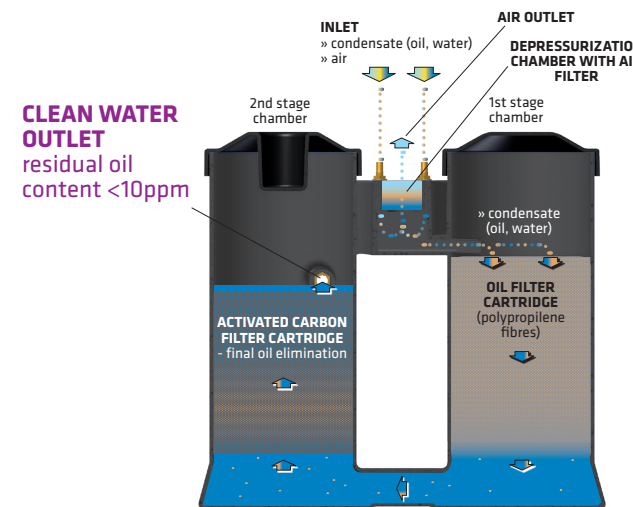

Condensate management

Condensate drains
Water-oil separators

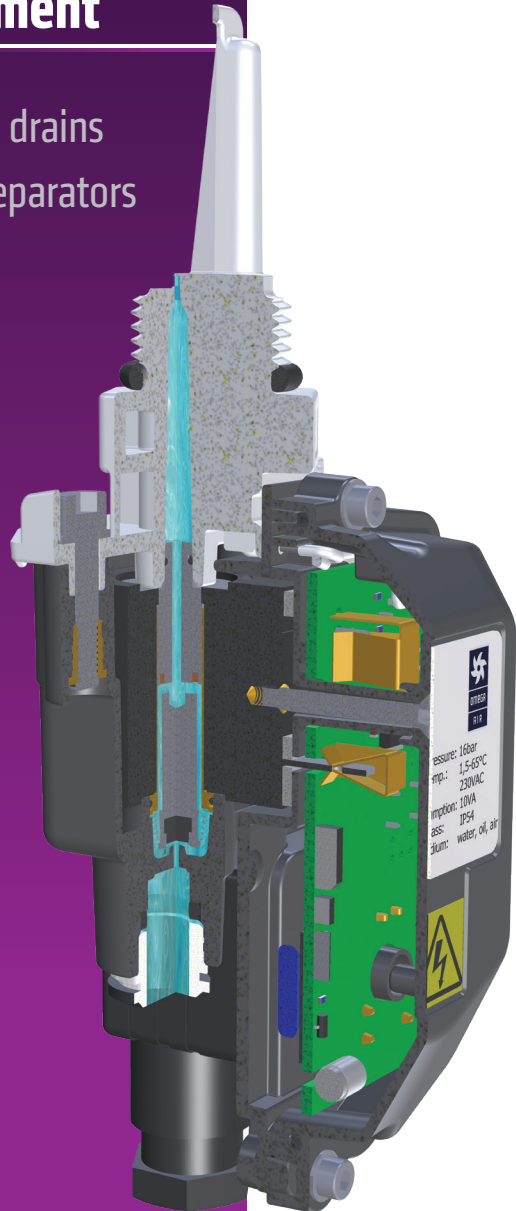

WATER/OIL SEPARATORS

WOSm	Water - oil separators
WOS	Water - oil separators
WOS CD	Condensate distributor

CONDENSATE DRAINS

		Pressure
EMD	Electronic condensate drains	16 bar
IED	Electronic condensate drain	16 bar
TD M	Timer controlled condensate drain	16, 25, 50, 150 bar
AOK 16B	Automatic mechanical condensate drain	16 bar
AOK 16F	Automatic mechanical condensate drain	16 bar
AOK 13PA	Automatic mechanical condensate drain	13 bar
AOK 20B	Automatic mechanical condensate drain	20 bar
AOK 20SS	Automatic mechanical stainless steel condensate drain	20 bar
MCD-B	Manual condensate drain	16 bar
MCD	Manual condensate drain	20 bar
MCDI	Manual condensate drain	20 bar
MCDIs	Manual condensate drain	20 bar
TD 420M	High pressure timer controlled condensate drains	0-420 bar
EMD HP	High pressure electronic condensate drains	50 bar
AOK 50B/SS	Automatic mechanical high pressure condensate drain	50 bar
BALL VALVE	Valve	16 bar
DRAIN VALVE	Valve	64, 420 bar

Water-oil separators

WOSm

Water-oil separators



WOS

Water-oil separators



WOS CD

Condensate distributor



Condensate drains

<p>EMD Electronic condensate drains</p> 	<p>IED Electronic condensate drains</p> 	<p>TD M Timer controlled condensate drains</p> 	<p>AOK 16B Automatic mechanical condensate drains</p> 	<p>AOK 16F Automatic mechanical condensate drains</p> 	<p>AOK 13PA Automatic mechanical plastic cond. drains</p> 
<p>Oper. pressure 16 bar Capacity 12 - 150 l/h</p>	<p>Oper. pressure 16 bar Capacity 8 l/h</p>	<p>Oper. pressure 16, 25, 50, 150 bar Capacity 0,7 - 3,4 l/h</p>	<p>Oper. pressure 1,5 - 16 bar Capacity</p>	<p>Oper. pressure 1,5 - 16 bar Capacity 7 - 9,1 l/h</p>	<p>Oper. pressure 13 bar Capacity 167 - 226 l/h</p>
<p>AOK 20B Automatic mechanical condensate drains</p> 	<p>AOK 20SS Autom. mech. stainless steel cond. drains</p> 	<p>MCD-B Manual condensate drain</p> 	<p>MCD Manual condensate drain</p> 	<p>MCDI Manual stainless steel condensate drain</p> 	<p>MCDIs Manual stainless steel condensate drain</p>  <p>silicone free</p>
<p>Oper. pressure 20 bar Capacity 167 l/h</p>	<p>Oper. pressure 20 bar Capacity 167 l/h</p>	<p>Oper. pressure 16 bar Capacity</p>	<p>Oper. pressure 20 bar Capacity</p>	<p>Oper. pressure 20 bar Capacity</p>	<p>Oper. pressure 20 bar Capacity</p>
<p>TD 420M Timer controlled high press. cond. drains</p> 	<p>EMD HP High pressure electronic cond. drains</p> 	<p>AOK 50B Autom. mech. high pressure cond. drain</p> 	<p>AOK 50SS Autom. stainless steel high press. c. drain</p> 	<p>BALL VALVE Valve</p> 	<p>BALL VALVE NV 420 High pressure valve</p> 
<p>Oper. pressure 0 - 420 bar Capacity x l/h</p>	<p>Oper. pressure 50 bar Capacity see product data sheet</p>	<p>Oper. pressure 8 - 50 bar Capacity 145 l/h</p>	<p>Oper. pressure 8 - 50 bar Capacity 145 l/h</p>	<p>Oper. pressure 16 bar Capacity</p>	<p>Oper. pressure 0 - 420 bar Capacity</p>

Drying

Basics

Drying compressed air - basics

Atmospheric air is the mixture of gasses surrounding the earth. Its density at sea level and 15°C is 1,225 kg/m³ (according to ISA). It is comprised of different gasses like nitrogen, oxygen, argon, carbon dioxide, and inevitably water vapour. Water vapour comes from boiling or evaporating liquid water or from sublimation of ice.

Humidity is the amount of water vapour in the air. Maximum humidity is determined solely by air temperature and is independent from all other parameters. Warmer air can accumulate more water vapour than cold air (see table below). When water evaporates, it cools the surface from which it evaporates. When water vapour condensates it heats the surface

on which it condensates. Water vapour only condensates on surfaces with temperatures lower than dew point or when air is theoretically over saturated.

Saturated air is a condition, when air contains a maximum amount of water vapour at a certain temperature and cannot possibly accumulate any more humidity. In this case, relative humidity is 100%. Relative humidity indicates the degree of saturation of air at a certain temperature. It ranges from 0-100%. Non-saturated air is a condition, where air could accumulate more water vapour by any means (boiling or evaporating from liquid water or sublimation from ice). Relative humidity is below 100%. Theoretically over-saturated air is the

state when the air contains more than the maximum theoretical limit of water vapour. The excessive amount of water vapour condensates to liquid water, while the air becomes saturated.

When water vapour condensates on a solid surface it is called dew. This happens when relative humidity reaches 100%. At a constant temperature, a volume of air can accumulate a finite amount of water vapour. When air becomes saturated it reaches the dew point and water vapour starts to condensate on solid surfaces, dust, soot and other impurities in air. Since hot air can accumulate more water vapour than cold air, hot air is dryer than cold air with the same dew point.

Dew point

Compressed air contains contaminants such as water, oil and particulates which must be removed or reduced to the acceptable level based on specific application requirements.

The standard ISO 8573-1 specifies air purity/quality classes for these contaminants. Humidity (water vapor content) is expressed in terms of Pressure Dew Point (PDP) where Dew point is the temperature at which air is 100% saturated with moisture. The dew point temperature is the temperature at which the air can no longer "hold" all of the water vapour which is mixed with it, and some of the water vapour must condense into liquid water. When the temperature of the air is reduced to or below the dew point, condensation will occur. As pressure increases, dew point temperature rises and air becomes more moist (RH increases), as pressure decreases, dew point temperature goes lower and air becomes drier (RH decreases).

Reduction of water content down to the pressure dew point +3°C is usually achieved with refrigerant dryers while for lower pressure dew points adsorption (also called desiccant) dryers are typically used.

The Mollier diagram is a graphic representation of the relationship between air temperature, moisture content and enthalpy - and is a basic design tool for construction engineers and designers.

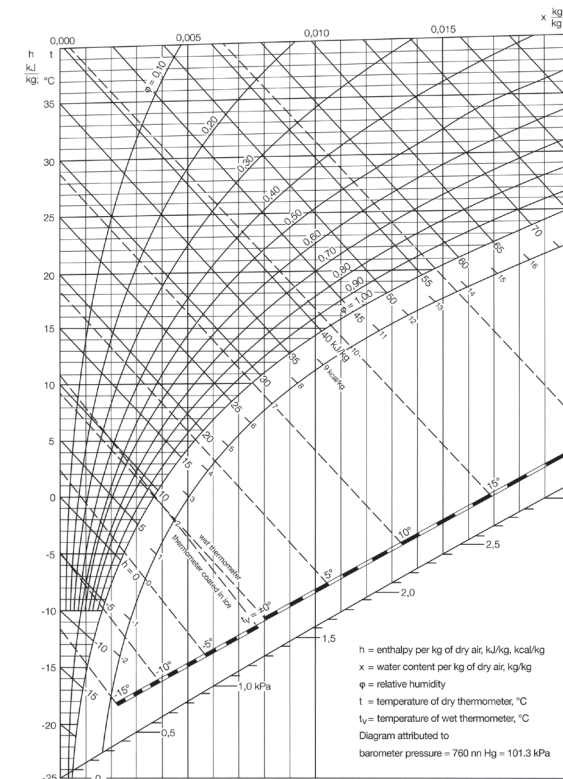

Compressed air dryer installation layout

Two most common dryer installation layouts are used for efficient integration into compressed air installation.

1) **Dryer is installed downstream from pressure vessel** when only partial flow rate of compressor is treated or when compressor operates at reduced intermittence and the total consumption equals the compressor flow rate.

- 1 Compressor
- 2 Aftercooler
- 3 Condensate separator
- 4 Filter
- 5 Pressure vessel
- 6 Condensate drain
- 7 Compressed Air Dryer
- 8 Compressed air outlet
- 9 DRY compressed air outlet

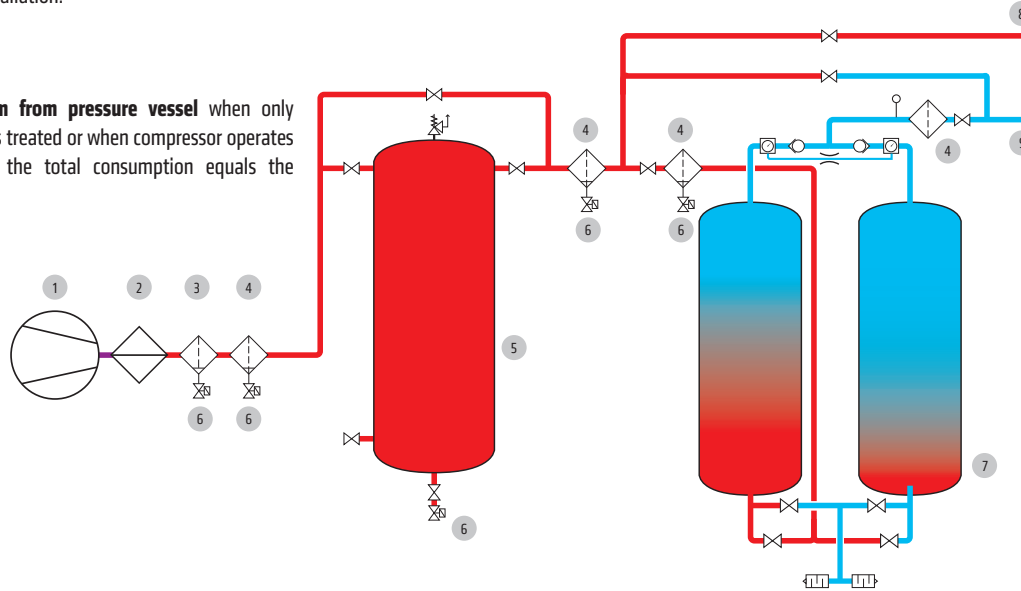

2) **Dryer is installed upstream from pressure vessel** when total flow rate of the compressor is treated or when consumption of compressed air varies a lot or when short peaks of high consumption (higher than dryer/compressor capacity) are expected.

- 1 Compressor
- 2 Aftercooler
- 3 Condensate separator
- 4 Filter
- 5 Pressure vessel
- 6 Condensate separator
- 7 Compressed Air Dryer
- 8 DRY compressed air outlet

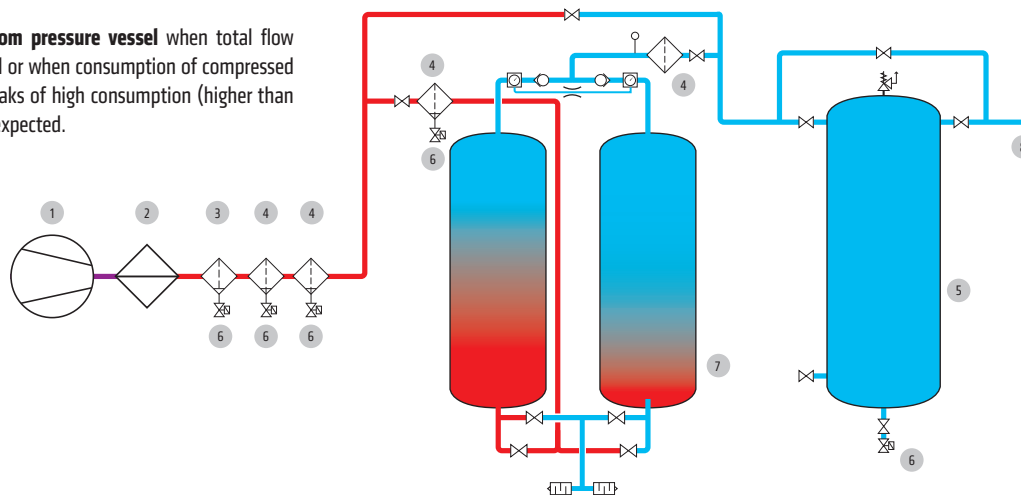

Compressed air dryers operating range

Refrigeration dryers

are suitable for all volume flow ranges with pressure dew point **down to 3°C**.

Adsorption dryers are suitable for all volume flow ranges with pressure dew point **down to -70°C**.

Membrane dryers are suitable for small volume flow ranges with pressure dew point **down to -40°C**.

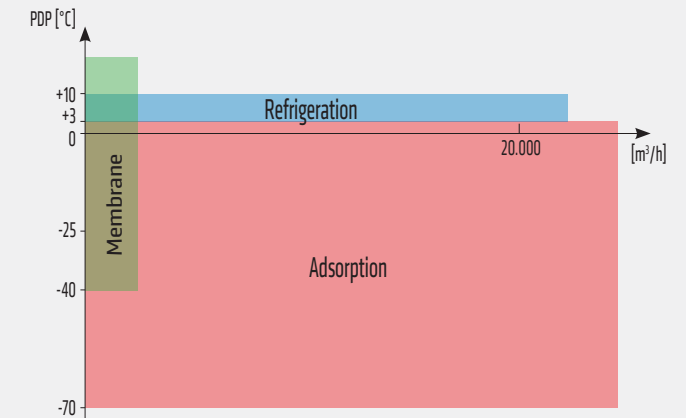

Drying

Refrigeration dryers Basics

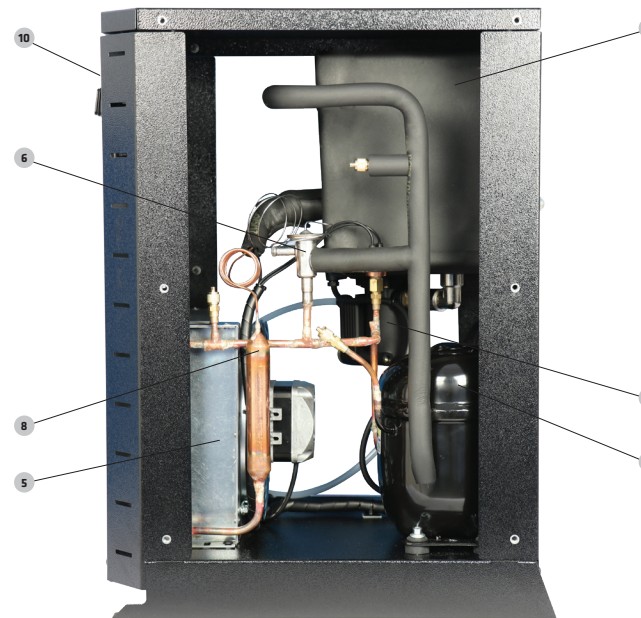
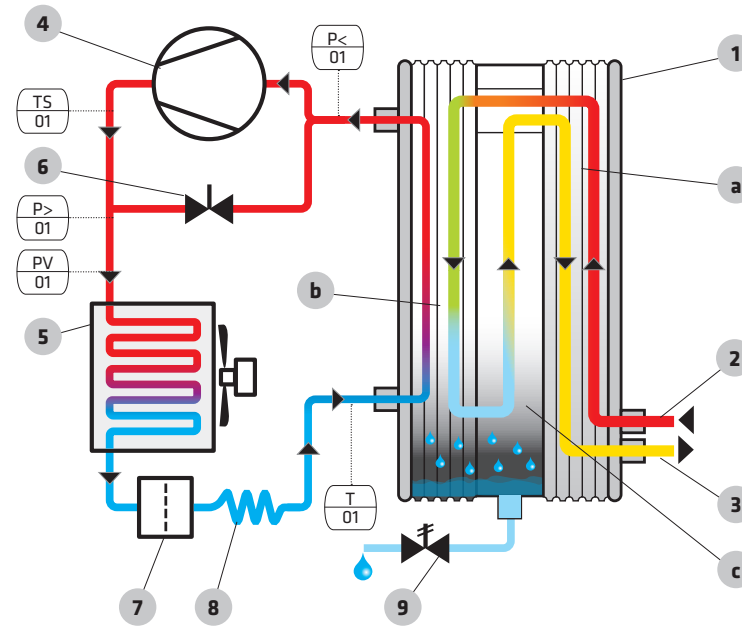

- 1 Heat exchanger module
- a Heat exchanger air/air - pre-cooler
- b Evaporator air/refrigerant
- c Demister
- 2 Compressed air input - wet
- 3 Compressed air output - dry
- 4 Compressor
- 5 Condenser
- 6 Hot gas by-pass valve
- 7 Gas filter
- 8 Expansion valve or capillary tube
- 9 Electronic condensate drain
- 10 Controller

Operation principle

The operating principle of a refrigeration compressed air dryer is based on the thermodynamic principle of cooling. The dryer uses a refrigerant to lower the temperature of compressed air, which in turn lowers the dew point of the air. The compressed air passes through a heat exchanger where it is cooled by the refrigerant. The moisture in the compressed air condenses into liquid form, which is then removed by a drain trap or automatic condensate drain.

Operation of refrigeration compressed air dryer can be divided into two independent circuits:

COMPRESSED AIR CIRCUIT

Warm and humid compressed air enters into three-stage heat exchanger. In the first stage "air-air" (a) incoming air is pre-cooled by cold outlet air. This stage is important from energy saving point of view as well as for stable operation of entire system. In the second stage "air-refrigerant" (b) the air is cooled by the cold refrigerant. In this stage water vapour condenses into liquid water. In the third stage "demister" (c) separates all the liquid water from the air stream. Cold dry air then enters "First stage" (a) again where it is re-heated by the hot inlet air. Besides energy saving feature this stage also makes sure that dry air leaving the dryer is warm enough to prevent condensation on the external side of downstream piping. Condensed water is discharged from the system via electronic condensate drain.

REFRIGERANT CIRCUIT

Circulation of the refrigerant gas in the circuit is provided by highly efficient hermetically sealed compressor (4). Compressor rises the pressure of the gas which is then cooled down and condensed in the condenser (5). Electric fan on the condenser can be controlled

by temperature or pressure sensor. Liquid refrigerant then flows through capillary tube or thermostatic expansion valve (8) which acts as a metering device to reduce the pressure of the refrigerant. Reduction of the pressure is a design function to achieve target temperature inside the evaporator (lower pressure = lower temperature). Filter (7) which is installed upstream the metering device intercepts impurities and assures reliable operation of the system. Low pressure refrigerant in gas form then re-enters the compressor.

RDP dryers operate based on "non-cycling" operating principle which means that when the dryer is without load (e.g. no or low inlet flow of compressed air) "hot gas by-pass valve" (6) will release part of the hot refrigerant gas (from discharge side of the compressor) back to the suction side of the compressor. As a result evaporation pressure/temperature will be constant at the factory pre-set value.

In case of high discharge temperature the controller stops the compressor before permanent damage occurs. Depending on size of the dryer additional safety/protection devices (e.g. low pressure switch, high pressure switch) are installed in on the refrigerant gas circuit.

All of our dryers are equipped with good control mechanisms. This allows for a very stable dew point. From the smallest dryer sizes on we offer excellent communication possibilities. Larger dryers are equipped with more powerful controllers offering advanced control and monitoring features.

Drying

Refrigeration dryers

Types



Applications

Refrigeration compressed air dryers are commonly used in a variety of industrial and commercial applications, including:

Food and beverage industry - to dry compressed air used in processing, packaging, and storage of food and beverages.

Pharmaceutical industry - to dry compressed air used in the production of drugs and medical equipment.

Electronics industry - to dry compressed air used in the manufacture of semiconductors and other electronic components.

Automotive industry - to dry compressed air used in painting, welding, and other manufacturing processes.

Printing industry - to dry compressed air used in printing presses.

Types of Refrigeration Compressed Air Dryers

There are two main types of refrigeration compressed air dryers: cycling and non-cycling. The cycling dryer operates by turning the compressor on and off based on the demand for compressed air. The non-cycling dryer, on the other hand, operates continuously regardless of the demand for compressed air.

REFRIGERATION DRYERS

RDP	Refrigeration compressed air dryers	16/14 bar
RDT	Refrigeration compressed air dryers with timer drain	16 bar
RDL	Refrigeration compressed air dryers	13 bar
RDHP	High pressure refrigeration compressed air dryers	45 bar



RDP

Refrigeration compressed air dryers



Oper. pressure 16/14 bar

RDT

Refrigeration dryers with timer drain



Oper. pressure 16 bar

RDL

Refrigeration compressed air dryers



Oper. pressure 13 bar

RDHP

High pressure refrigeration dryers



Oper. pressure 45 bar

Drying

Adsorption dryers Basics



Adsorption compressed air dryers are a type of compressed air dryer that uses an adsorbent material to remove moisture from compressed air. Unlike refrigeration compressed air dryers that use cooling to remove moisture, adsorption dryers use a desiccant material to adsorb moisture from the compressed air.

DRYERS, COOLERS, OIL REMOVERS

A-DRY	Heatless regeneration adsorption compressed air dryers	4 to 16 bar	6 - 200 Nm ³ /h	-40 °C (-25 °C/-70 °C)
A-DRY TAC	Adsorption compressed air dryers with activated carbon tower	4 to 16 bar	6 - 117 Nm ³ /h	-40 °C (-25 °C/-70 °C)
A-DRY BM	Heatless regeneration adsorption compressed air dryers	4 to 16 bar	6 - 200 Nm ³ /h	-40 °C (-25 °C/-70 °C)
X-DRY	Heatless regeneration modular ads. compressed air dryers	4 to 16 bar	300 - 1.050 Nm ³ /h	-40 °C (-25 °C/-70 °C)
B-DRY	Heatless regeneration adsorption compressed air dryers	4 to 16 bar	110 - 1.000 Nm ³ /h	-40 °C (-25 °C/-70 °C)
B-DRY TAC	Heatless regener. ads. comp. air dryers with act. carbon tower	4 to 16 bar	1200 - 6.500 Nm ³ /h	-40 °C (-25 °C/-70 °C)
B-DRY BM	Heatless regeneration adsorption compressed air dryers	4 to 16 bar	110 - 1.000 Nm ³ /h	-40 °C (-25 °C/-70 °C)
F-DRY	Heatless regeneration adsorption compressed air dryers	4 to 16 bar	1200 - 6.500 Nm ³ /h	-40 °C (-25 °C/-70 °C)
COM-DRY	Refrigerant + adsorption compressed air dryers	4 to 11 bar	1200 - 6.500 Nm ³ /h	-40 °C (-25 °C/-70 °C)
R-DRY BVA	Heat reg. ads. dryers - cooling with ambient air	4 to 11 bar	390-20.200 Nm ³ /h	-40 °C
R-DRY BP	Heat reg. ads. dryers - cooling with purge air	4 to 11 bar	390-20.200 Nm ³ /h	-40 °C
R-DRY BVL	Heat reg. ads. dryers - cooling with closed loop	4 to 11 bar	390-20.200 Nm ³ /h	-40 °C
R-DRY HOC F/P	Heat reg. ads. dryers - heated with full/partial stream	4 to 11 bar	390-20.200 Nm ³ /h	-20 °C
HPR-DRY BVA	High pressure heat reg. ads. dryers - cooling with ambient air	50 bar	2.485 - 23.400 Nm ³ /h	-40 °C
HPR-DRY BP	High pressure heat reg. ads. dryers - cooling with purge air	50 bar	2.485 - 23.400 Nm ³ /h	-40 °C
HPR-DRY BVL	High pressure heat reg. ads. dryers - cooling with closed loop	50 bar	2.485 - 23.400 Nm ³ /h	-40 °C
HP-DRY	High pressure heatless regeneration adsorption dryers	50, 100, 150, 420 bar	50 - 1.600 Nm ³ /h	-40 °C
MAA-DRY	Membrane compressed air dryers	12 bar	3 - 180 Nm ³ /h	+15, +3, -20, -40 °C
ACA	Air cooled aftercoolers	15 bar	66 - 4.500 Nm ³ /h	
ACW	Water cooled aftercoolers	10 bar	132 - 45.570 Nm ³ /h	
TAC	Activated carbon towers	16 bar	6 - 2.800 Nm ³ /h	
TAC HP	High pressure activated carbon towers	50, 100, 150, 420 bar	50 - 1.600 Nm ³ /h	
SORBEO	Adsorbents			

Operating principle

The working principle of an adsorption compressed air dryer is based on the process of adsorption. The dryer contains a desiccant material, that has a high affinity for water molecules. The compressed air passes through a bed of the desiccant material, where the moisture in the air is adsorbed onto the surface of the material.

When the desiccant material becomes saturated with moisture, the adsorption process stops, and the dryer needs to regenerate the desiccant material to remove the moisture. The regeneration process involves heating the desiccant material, usually by using a heating element, to release the moisture from the material. The moisture is then vented out of the dryer, and the desiccant material is ready for use again.

Types of Adsorption Compressed Air Dryers

There are two main types of adsorption compressed air dryers: heatless and heated. Heatless dryers use the compressed air itself to regenerate the desiccant material. A portion of the compressed air is diverted to the dryer's regeneration section to dry the saturated desiccant material. The dry air is then used to purge the desiccant material, removing the moisture and preparing it for use again.

Heated dryers use an external heat source, such as an electric heater or natural gas burner, to regenerate the desiccant material. The heated air is then used to purge the desiccant material, removing the moisture and preparing it for use again.

Applications

Adsorption compressed air dryers are commonly used in applications that require very low dew points, or where compressed air is exposed to harsh environments, such as oil and gas, chemical processing, and pharmaceuticals. They are also used in situations where the compressed air cannot be exposed to oil or other contaminants, which can damage the desiccant material.

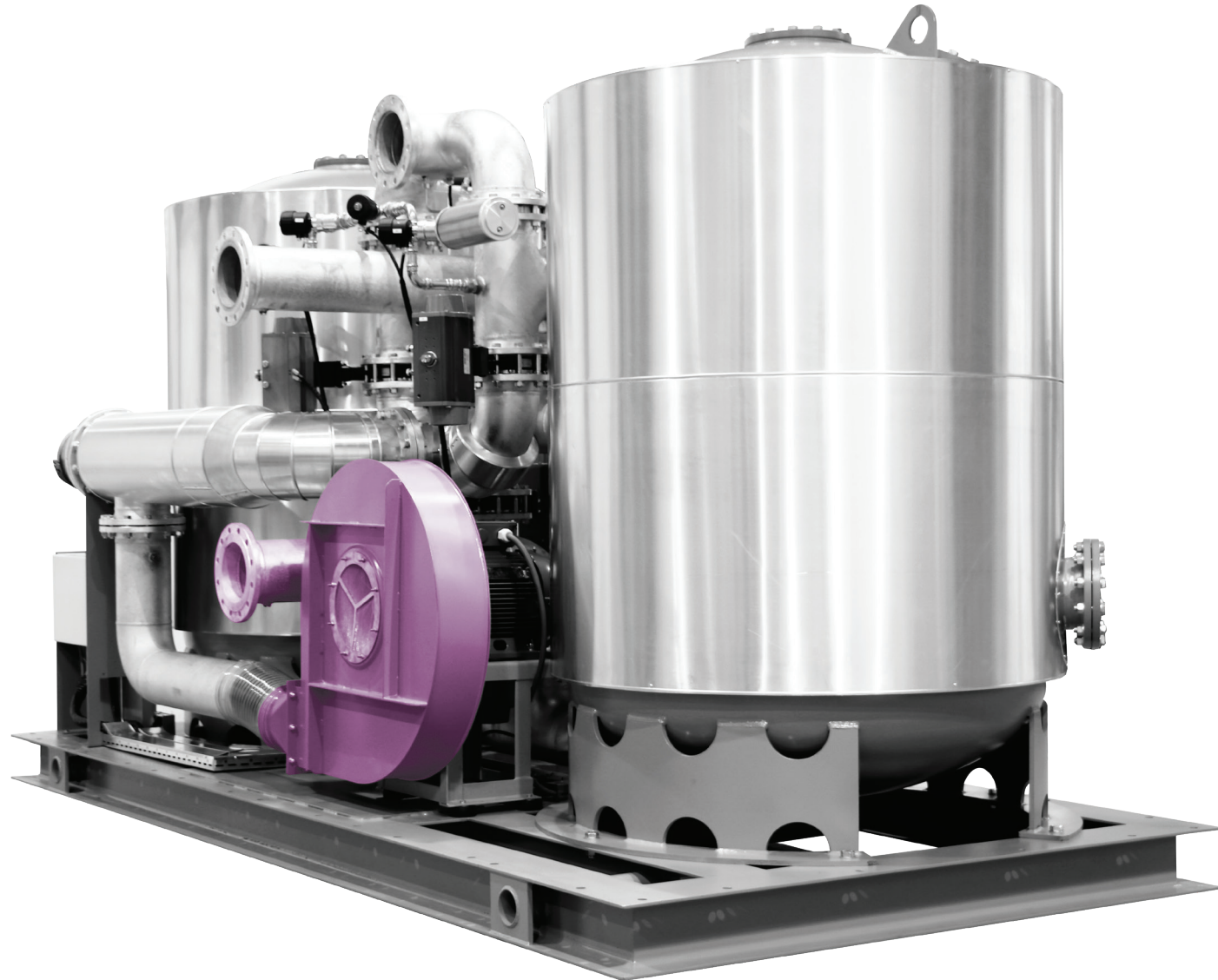

Drying

Adsorption dryers Ranges

HEATLESS REGENERATION COMPRESSED AIR DRYERS

Heatless regeneration is done with already dried compressed air which is taken from the dryer's outlet, decompressed to the atmospheric pressure and fed to the regeneration vessel. Extremely under-saturated air extracts moisture from the desiccant and discharges it to the environment via silencer. The full cycle is 10 minutes long, 5 minutes for adsorption and 5 for regeneration.

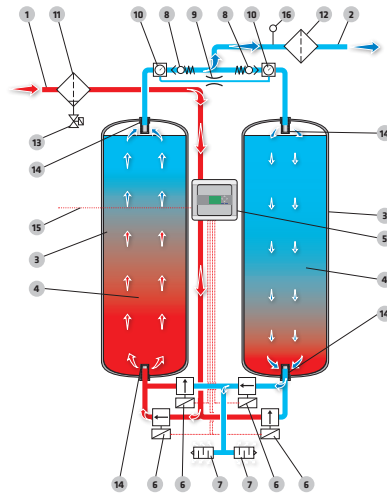

- | | | | |
|---|------------------------------|----|-------------------------------------|
| 1 | Comp. air inlet (wet air) | 9 | Nozzle |
| 2 | Comp. air outlet (dry air) | 10 | Pressure manometer |
| 3 | Column filled with desiccant | 11 | Inlet air filter |
| 4 | Two layer desiccant bed | 12 | Outlet air filter |
| 5 | Controller | 13 | Automatic cond. drain |
| 6 | Solenoid valve | 14 | Flow distribution insert |
| 7 | Expansion silencer | 15 | Cable for solenoid valve (optional) |
| 8 | Non-return valve | 16 | Dew point sensor (optional) |

HEAT REGENERATION COMPRESSED AIR DRYERS

R-DRY BP (cooling with purge)

BP dryers are using top to bottom air flow to regenerate the column. First, ambient air is sucked and directed through the heater and then into the column to heat it. Instead of ambient air, purge is used for cooling. Because dry and cool purge air is used, this kind of dryer can operate in environments where BVA cannot, for example, with higher temperature and humidity. Its disadvantage is that it is sensitive to variation of operating pressure or the variation of purge air flow.

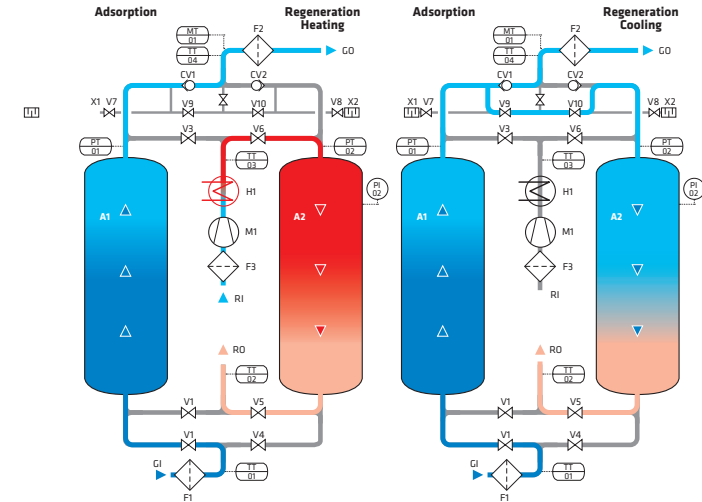

- | | | | |
|-------|---|-------|-------------------------|
| A1-2 | pressure vessel | M1 | blower |
| F1 | inlet filter (super fine coalescing) | H1 | heater |
| F2 | outlet filter (dust) | F3 | regeneration air filter |
| V1-6 | ball valve with pneumatic actuator | GI | air inlet |
| V7-10 | angle seated valve with pneum. actuator | GO | air outlet |
| CV1-2 | check valve | RI | regeneration air inlet |
| TT1-4 | temperature transducer | RO | regeneration air outlet |
| PT1-2 | pressure indicator | ES1-2 | expansion silencer |
| DT1 | dewpoint transducer | | |

R-DRY BVA (vacuum regeneration with ambient air)

BVA is using ambient air to heat up and cool down the column which is being regenerated. The ambient air is sucked from the upper side of the column, first through the heater, then through the adsorbent and then it is discharged into the environment.

Because it uses ambient air, it cannot be used in environments with high ambient temperature and humidity. Air in these environments is already quite saturated and the regeneration wouldn't be so efficient. Its advantage is that it can be used in areas with changeable operating flow and pressure.

R-DRY BVL (vacuum regeneration with closed loop)

BVL is using ambient air for heating and for cooling the air that is in the vessel. Ambient air is sucked in, heated and directed through the vessel from the top side and then discharged into the environment. To cool the vessel, some valves change their state and the trapped air is used for cooling. Air goes through the heat exchanger where it is cooled and then used to cool the vessel. Air coming from the vessel is directed to the heat exchanger. Due to closed loop during cooling, no water is entering the system. This means higher adsorbent capacity, which is suitable for hotter and more humid environments. Because the heat exchanger uses an external source of cooling, water is required.

RC-DRY (regen. by heat of compression - full flow)

RC dryers are those with zero compressed air loss. RC dryer uses air directly from compressor. This means that no source of heat is needed because the air coming from the compressor is already heated. Heated air enters the regeneration column where it heats, then it flows through the heat exchanger and cools down to a certain point. Finally, the air is dried in an adsorption column.

Because it uses the heat of compression, it is characterized by a high level of energy efficiency. This kind of dryer has to be dimensioned and modified to closely match the compressor and operating conditions. Compressors used with RC dryers must be oil free compressors.

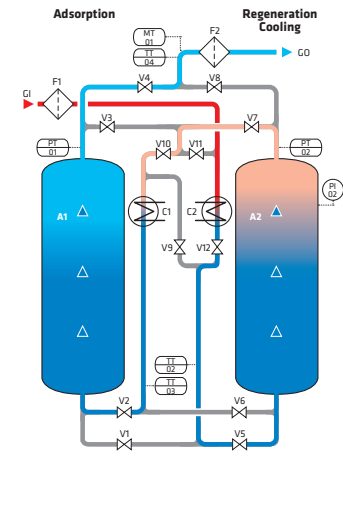
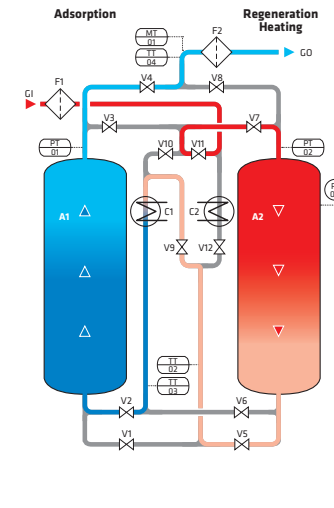
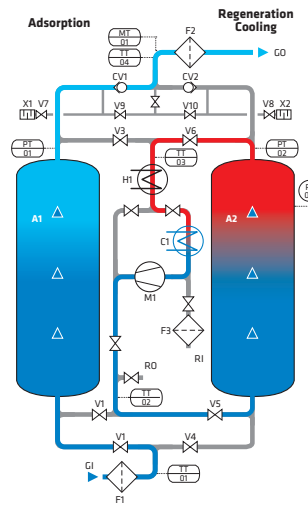
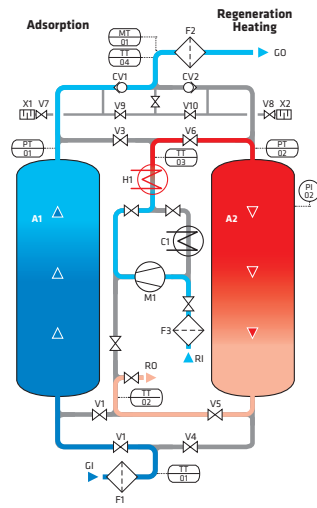
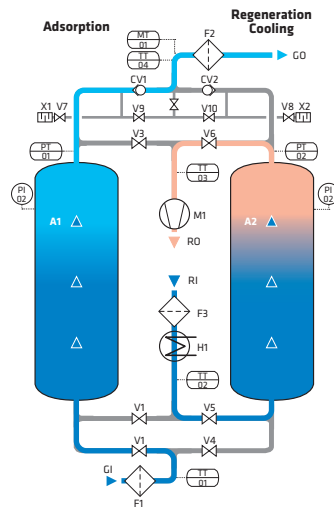
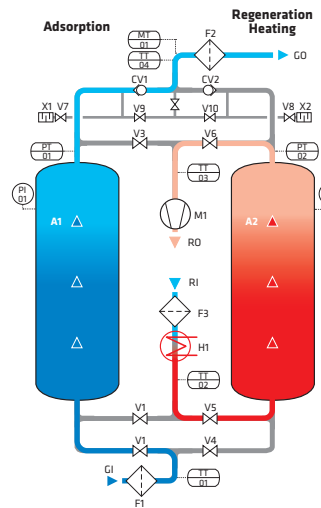

- A1-2 pressure vessel
- F1 inlet filter (super fine coalescing)
- F2 outlet filter (dust)
- V1-6 ball valve with pneumatic actuator
- V7-10 angle seated valve with pneumatic actuator
- CV1-2 check valve
- TT1-4 temperature transducer
- PI1-2 pressure indicator
- PT1-2 pressure transducer

- DT1 dewpoint transducer
- M1 blower
- H1 heater
- F3 regeneration air filter
- GI air inlet
- GO air outlet
- RI regeneration air inlet
- RO regeneration air outlet
- ES1-2 expansion silencer

- A1-2 pressure vessel
- F1 inlet filter (super fine coalescing)
- F2 outlet filter (dust)
- V1-6 ball valve with pneumatic actuator
- V7-10 angle seated valve with pneumatic actuator
- CV1-2 check valve
- TT1-4 temperature transducer
- PI1-2 pressure indicator
- PT1-2 pressure transducer
- DT1 dewpoint transducer

- M1 blower
- H1 heater
- F3 regeneration air filter
- GI air inlet
- GO air outlet
- RI regeneration air inlet
- RO regeneration air outlet
- ES1-2 expansion silencer
- C1 water cooled heat exchanger

- A1-2 pressure vessel
- F1 inlet filter (super fine coalescing)
- F2 outlet filter (dust)
- V1-6 ball valve with pneumatic actuator
- V7-10 angle seated valve with pneumatic actuator
- CV1-2 check valve
- TT1-4 temperature transducer
- PI1-2 pressure indicator
- PT1-2 pressure transducer

- DT1 dewpoint transducer
- GI air inlet
- GO air outlet
- RO regeneration air outlet
- C1-2 water cooled heat exchanger

Drying

- Adsorption dryers
- Membrane dryers
- Hybrid dryers
- Adsorbers

Types

A-DRY	A-DRY TAC	A-DRY BM	X-DRY	COM-DRY
Heatless regeneration adsorption compressed air dryers	Adsorption compressed air dryers with activated carbon tower	Heatless regeneration adsorption compressed air dryers	Heatless regeneration modular adsorption compressed air dryers	Refrigerant + adsorption compressed air dryers
				
Oper. pressure 4 to 16 bar	Oper. pressure 4 to 16 bar	Oper. pressure 4 to 16 bar	Oper. pressure 4 to 16 bar	Oper. pressure 4 to 11 bar
Capacity 6 - 200 Nm ³ /h	Capacity 6 - 117 Nm ³ /h	Capacity 6 - 200 Nm ³ /h	Capacity 300 - 1.050 Nm ³ /h	Capacity 1200 - 6.500 Nm ³ /h
Dew point -40 °C (-25 °C/-70 °C)	Dew point -40 °C (-25 °C/-70 °C)	Dew point -40 °C (-25 °C/-70 °C)	Dew point -40 °C (-25 °C/-70 °C)	Dew point -40 °C (-25 °C/-70 °C)
B-DRY	B-DRY TAC	B-DRY BM	F-DRY	HPR-DRY BP
Heatless regeneration adsorption compressed air dryers	Heatless regeneration adsorption comp. air dryers with activated carbon tower	Heatless regeneration adsorption compressed air dryers	Heatless regeneration adsorption compressed air dryers	High pressure heat regen. ads. dryers - cooling with purge air
				
Oper. pressure 4 to 16 bar	Oper. pressure 4 to 16 bar	Oper. pressure 4 to 16 bar	Oper. pressure 4 to 16 bar	Oper. pressure 50 bar
Capacity 110 - 1.000 Nm ³ /h	Capacity 1200 - 6.500 Nm ³ /h	Capacity 110 - 1.000 Nm ³ /h	Capacity 1200 - 6.500 Nm ³ /h	Capacity 2.485 - 23.400 Nm ³ /h
Dew point -40 °C (-25 °C/-70 °C)	Dew point -40 °C (-25 °C/-70 °C)	Dew point -40 °C (-25 °C/-70 °C)	Dew point -40 °C (-25 °C/-70 °C)	Dew point -40 °C

R-DRY BP

Heat regeneration adsorption dryers - cooling with purge air



Oper. pressure 4 to 11 bar
Capacity 390-20.200 Nm³/h
Dew point -40 °C

R-DRY BVA

Heat regeneration adsorption dryers - cooling with ambient air



Oper. pressure 4 to 11 bar
Capacity 390 - 20.200 Nm³/h
Dew point -40 °C

R-DRY BVL

Heat regeneration adsorption dryers - cooling with closed loop



Oper. pressure 4 to 11 bar
Capacity 390-20.200 Nm³/h
Dew point -40 °C

R-DRY HOC F/P

Heat regeneration adsorption dryers - heated with full/partial stream



Oper. pressure 4 to 11 bar
Capacity 390-20.200 Nm³/h
Dew point -40 °C

HPR-DRY BVA

High pressure heat regen. ads. dryers - cooling with ambient air



Oper. pressure 50 bar
Capacity 2.485 - 23.400 Nm³/h
Dew point -40 °C

HPR-DRY BVL

High pressure heat regen. ads. dryers - cooling with closed loop



Oper. pressure 50 bar
Capacity 2.485 - 23.400 Nm³/h
Dew point -40 °C

HP-DRY

High pressure heatless regeneration adsorption dryers



Oper. pressure 50, 100, 150, 420 bar
Capacity 50 - 1.600 Nm³/h
Dew point -40 °C

MAA-DRY

Membrane dryers



Oper. pressure 12 bar
Capacity 3 - 180 Nm³/h
Dew point +15, +3, -20, -40 °C

COM-DRY

Hybrid dryers



Oper. pressure 4 - 11 bar
Capacity 6 - 6.500 Nm³/h
Dew point down to -40 °C

TACm

Activated carbon towers



Oper. pressure 16 bar
Capacity 6 - 200 Nm³/h

TAC

Activated carbon towers



Oper. pressure 16 bar
Capacity 110 - 1.000 Nm³/h

TAC HP

High pressure activated carbon towers



Oper. pressure 50, 100, 250, 420 bar
Capacity 50 - 1.600 Nm³/h

Drying

Adsorbents

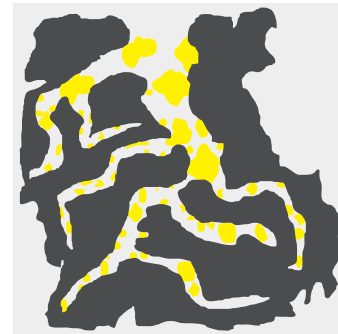

Adsorbents are widely used in the compressed air and gas industry to remove impurities, such as moisture, oil, and particulate matter, from compressed air and gas streams. The most commonly used adsorbents in this industry include:

Activated Carbon: Activated carbon is commonly used in the compressed air and gas industry to remove oil vapor and other organic compounds from compressed air and gas streams. It is often used in conjunction with other adsorbents, such as molecular sieves or silica gel, to achieve high levels of purification.

Molecular Sieves: Molecular sieves are synthetic zeolites that are highly selective in their adsorption of water vapor, as well as other impurities, such as CO₂, H₂S, and mercaptans. They are commonly used in regenerative adsorption systems, such as PSA (pressure swing adsorption) or TSA (temperature swing adsorption) systems.

Silica Gel: Silica gel is a highly porous material that is capable of adsorbing water vapor and other impurities from compressed air and gas streams. It is commonly used in small-scale applications or as a desiccant in disposable cartridges.

Activated Alumina: Activated alumina is a highly porous material that is capable of adsorbing water vapor and other impurities from compressed air and gas streams. It is often used in pressure swing adsorption (PSA) dryers.

Calcium Chloride: Calcium chloride is a highly hygroscopic salt that is capable of absorbing water vapor from the air. It is commonly used in industrial refrigeration systems or as a desiccant in disposable cartridges.

The choice of adsorbent will depend on the specific application and the desired level of purity. Factors such as the flow rate of the compressed air or gas, the operating pressure, and the required level of purification will also need to be taken into consideration when selecting an adsorbent.



<p>SORBEO MS 3A</p> <p>Molecular sieve</p>  <p>Shape granule 2,5 - 5,0 mm Bulk density 0,7 kg/l</p>	<p>SORBEO MS 4A</p> <p>Molecular sieve</p>  <p>Shape granule 2,5 - 5,0 mm Bulk density 0,7 kg/l</p>	<p>SORBEO MS 10A</p> <p>Molecular sieve</p>  <p>Shape granule 2,5 - 5,0 mm Bulk density 0,64 kg/l</p>	<p>SORBEO MS 10 O₂</p> <p>Molecular sieve</p>  <p>Shape granule 1,6 - 2,6 mm Bulk density 0,68 kg/l</p>	<p>SORBEO AA</p> <p>Activated Alumina</p>  <p>Shape granule 2,0 - 5,0 mm Bulk density 0,77 kg/l</p>	<p>SORBEO SGWS</p> <p>Water resistance silica gel</p>  <p>Shape granule 2,0 - 5,0 mm Bulk density 0,7 kg/l</p>
<p>SORBEO SGR</p> <p>Silica gel</p>  <p>Shape granule 2,0 - 5,0 mm Bulk density 0,7 kg/l</p>	<p>SORBEO AC</p> <p>Activated carbon</p>  <p>Shape pellet 3,0 mm Bulk density 0,5 kg/l</p>	<p>SORBEO HC</p> <p>Catalyst</p>  <p>Shape pellets 3,0 mm Bulk density 0,9 kg/l</p>	<p>SORBEO CMS</p> <p>Carbon molecular sieve</p>  <p>Shape pellets 1,18 ± 0,2 mm Bulk density 0,68 - 0,71 kg/l</p>	<p>SORBEO SGC</p> <p>Silica gel</p>  <p>Shape granulate 2 - 5 mm Bulk density 0,8 kg/l</p>	<p>SORBEO SL</p> <p>Soda lime</p>  <p>Shape Menispherical pellets Bulk density 0,93 kg/l</p>

Gas generators

Nitrogen generators

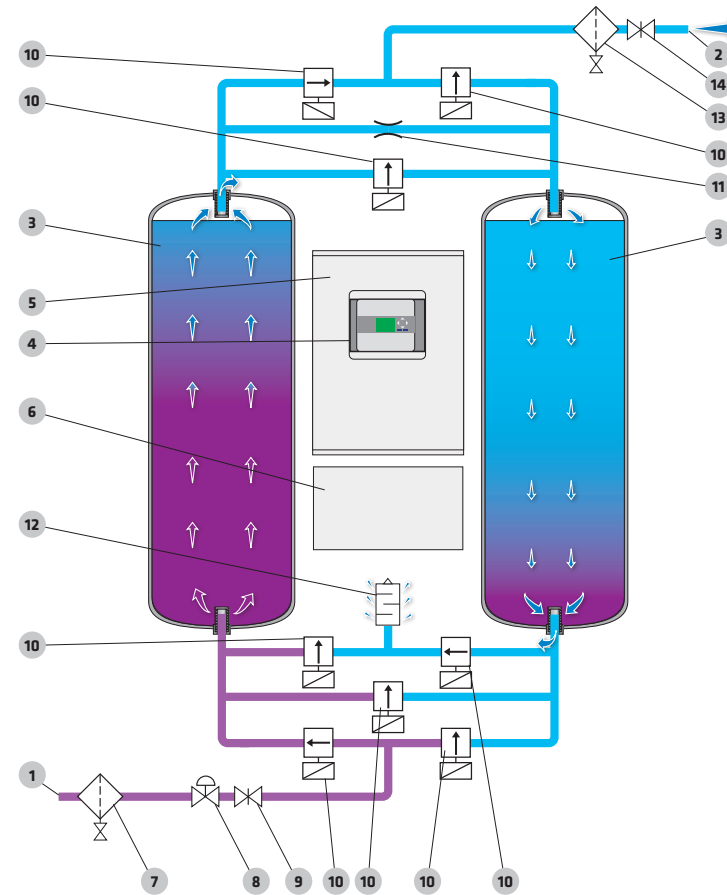

- 1 Cleaned compressed air inlet
- 2 Gas outlet
- 3 Column filled with molecular sieve
- 4 Siemens Interface KTP 400
- 5 Electrical cabinet
- 6 Pneumatic cabinet
- 7 Microfilter
- 8 Pressure regulator
- 9 Compressed air flow regulator
- 10 Angle seated valve with pneumatic actuator
- 11 Purge nozzle
- 12 Exhaust silencer
- 13 Prefilter
- 14 Gas flow regulator

GENERATORS		Pressure	Capacity	Purity	Dew point
N-GEN	PSA nitrogen generators	6-10 bar	0,83 - 766,8 Nm ³ /h	up to 99,999 %	<-45°C
NM-GEN	Membrane nitrogen generators	5-24 bar	0,8 - 780 Nm ³ /h	up to 99,5 %	<-50°C

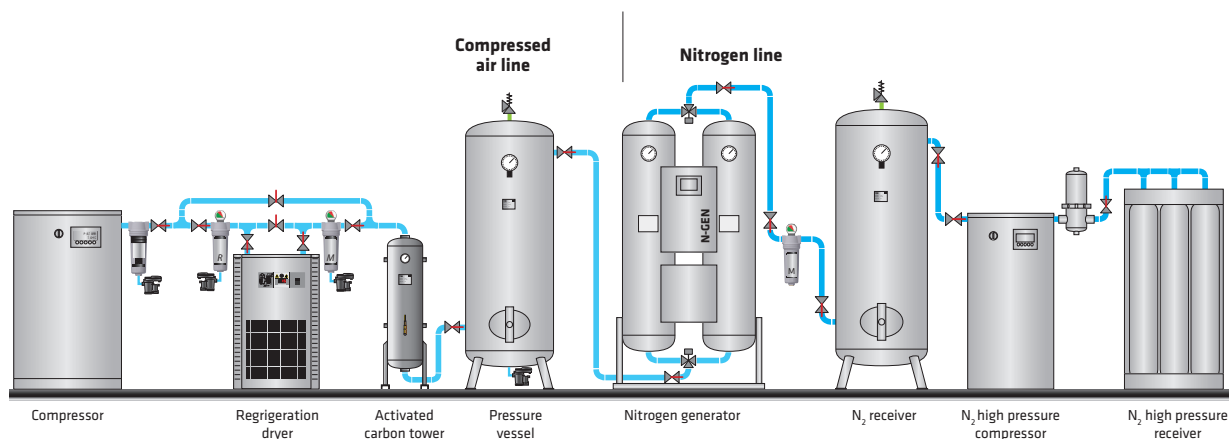

NITROGEN

Nitrogen is an inert gas that is suitable for a wide range of applications, covering various aspects of chemical manufacturing, processing, handling, and shipping. Nitrogen has low reactivity and it is excellent for blanketing and is often used as purging gas. It can be used to remove contaminants from process streams through methods such as stripping and sparging. Due to its properties it can be used for protection of valuable products against harmful contaminants. It also enables safe storage, usage of flammable compounds and can help prevent combustible dust explosions.

Generating nitrogen gas

Industrial nitrogen gas can be produced by either separation of gaseous air using adsorption (PSA) or fractional distillation of liquefied air using cryogenic methods.

Pressure swing adsorption

The first step in the PSA process is compressed air passing through a combination of filters and an activated carbon tower with the purpose of removing dust, entrained oil and water. The purified air is then directed to one of two adsorption vessels that are packed with carbon molecular sieves (CMS). The remaining impurities such as carbon dioxide and residual moisture are adsorbed by the CMS at the entrance of the adsorbent bed.

When the CMS is at high pressure, it selectively adsorbs oxygen, allowing nitrogen to pass through it at the desired purity level. While one vessel is at high pressure to produce nitrogen, the second vessel is depressurized to remove the adsorbed oxygen, which is then vented to the atmosphere. The automatic switching between adsorption and desorption between the two beds enables the continuous production of nitrogen. By adjusting the size of the air compressor and adsorption vessels containing the CMS, a large range of flow and purity combinations can be met. PSAs can economically produce nitrogen gas at flowrates from less than one cubic meter per hour to greater than a few thousand cubic meter per hour at purities ranging from 96% to 99.999%.

N-GEN

PSA Nitrogen generators



Oper. pressure	6 - 10 bar
Capacity	0,83 - 766,8 Nm ³ /h
Dew point	<-45 °C
Nitrogen purity	up to 99,999 %

NM-GEN

Membrane Nitrogen generators



Oper. pressure	5 - 24 bar
Capacity	0,8 - 780 Nm ³ /h
Dew point	<-50 °C
Nitrogen purity	up to 99,5 %



Gas generators

Oxygen generators

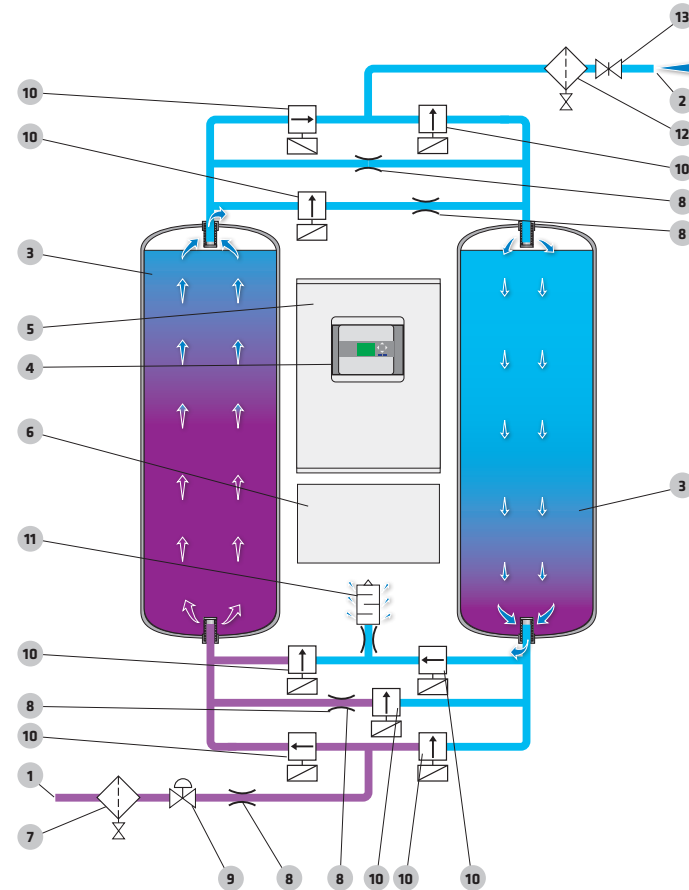

- 1 Cleaned compressed air inlet
- 2 Oxygen outlet
- 3 Column filled with molecular sieve
- 4 Siemens Interface KTP 400
- 5 Electrical cabinet
- 6 Pneumatic cabinet
- 7 Microfilter
- 8 Nozzle
- 9 Pressure regulator
- 10 Angle seated valve with pneumatic actuator
- 11 Exhaust silencer
- 12 Dust filter
- 13 Oxygen flow regulator

GENERATORS		Pressure	Capacity	Purity	Dew point
O-GEN	PSA oxygen generators	5-6 bar	1,02 - 94,9 Nm ³ /h	up to 95 %	<-60°C

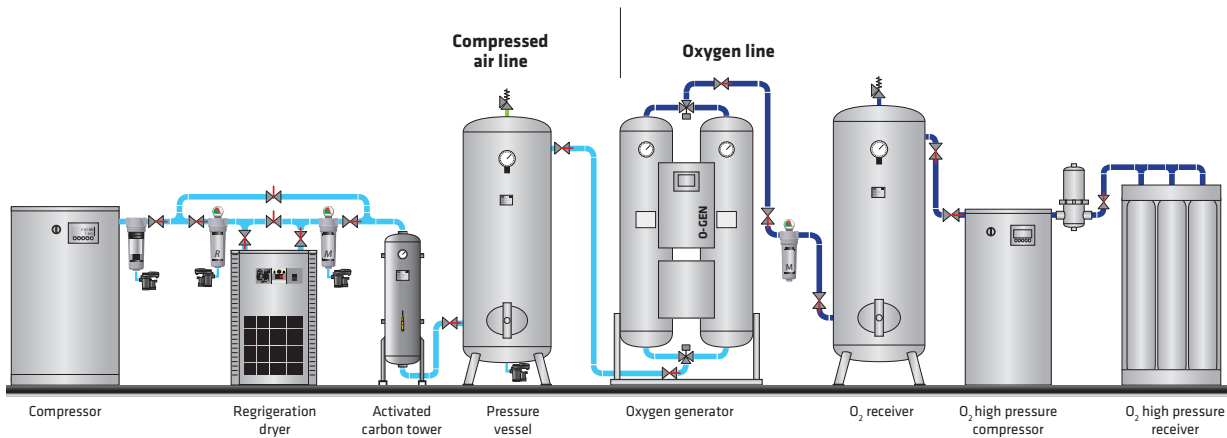

O-GEN

PSA Oxygen generators



Oper. pressure	5 - 6 bar
Capacity	1,02 - 94,9 Nm ³ /h
Dew point	<-60 °C
Oxygen purity	up to 95 %



OXYGEN

Oxygen, is present in the air with concentration around 21%. Oxygen is at atmospheric conditions always present in gas phase with no odour, colour or taste. It is a highly reactive substance, reacting with almost all elements, except inert gases. This is why it is used in a variety of applications: aquaculture, feed gas for ozone generators, glass blowing, leaching, NO_x reduction for fuel burners, oxygen lancing, welding and health care.

Generating Oxygen gas

Oxygen gas can be produced by either separation of gaseous air using adsorption (PSA) or fractional distillation of liquefied air using cryogenic methods.

Pressure swing adsorption

The first step in the PSA process is compressed air passing through a combination of dryers, filters and an activated carbon tower with the purpose of removing dust, entrained oil and water. The purified air is then directed to one of two adsorption vessels that are packed with 5% of activated alumina (AA) and 95% of molecular sieves (MS). The remaining impurities such as carbon dioxide and residual moisture are adsorbed by the activated alumina (AA) at the entrance of the adsorbent bed. When the MS is at high pressure, it selectively adsorbs nitrogen, allowing oxygen to pass through it at the desired purity level. While one vessel is at high pressure to produce oxygen, the second vessel is depressurized to remove the adsorbed nitrogen, which is then vented to the atmosphere.

The automatic switching between adsorption and desorption between the two beds enables the continuous production of oxygen. By adjusting the size of the air compressor and adsorption vessels containing the MS, a large range of flow and purity combinations can be met. PSAs can economically produce oxygen gas at flow rates from less than one cubic meter per hour to greater than a few hundred cubic meter per hour at purities ranging from 90% to 95%.

Gas dryers

CO₂ dryers



Under normal conditions, carbon dioxide (CO₂) is a colourless and odourless gas, with a slightly sour taste, denser than air and non-flammable. It is present in the atmosphere in a concentration of about 400 ppm. CO₂ is not toxic in small quantity but higher concentration are dangerous for health due to the reduction of oxygen rate.

Thanks to its relative neutrality and abundance, this gas is used in numerous applications such as Food & Beverage (breweries), Welding, Cooling, Packaging and many others.

But because it usually needs to be compressed and liquefied to be stored, we have to treat it first, and specially dry it.

Heat Regenerated Dryers

Carbon Dioxide is a gas which can be highly corrosive, depending on its level of humidity. Compressed Carbon Dioxide Dryers (CO₂ Dryers) are therefore normally custom made, to meet specific project requirements.

Several versions are available, based on operating pressure, temperature, requested pressure dew point and level of humidity. Depending on this last criteria, the dryer's materials will need to be modified.

The type of regeneration is, by default, conducted with heat provided by an external heater (heating phase), and blown ambient air cooled by water (cooling phase). But depending on the existence and the type of the available fluids to conduct the heating/cooling, we can adapt the regeneration and the components of the CO₂ Dryer, to ensure that a strict minimum of gas will be lost during the whole process.



- Compact units – perfect for container-sized applications
- Food Grade available on request
- Adapted for 100 % water saturated gas
- Covers all pressures, for all applications
- Higher flows on request
- Design adaptable to each application/project

CO₂-DRY

Carbon dioxide dryers



Oper. pressure	4 - 40 bar
Capacity	100 to 12.550 Nm ³ /h
Dew point	-25 °C to -70 °C

The example of CCU from beverage fermentation

Once the fermentation is complete, the CO₂ produced is usually released into the atmosphere, which represents a risk for human health (many accidents to be deplored each year) and for the environment (CO₂ being a greenhouse gas). Instead, Omega Air proposes to purify and liquefy this CO₂, as the below simulation shows, in order for the owner of the installation to

recover and add value to this gas by reusing it or selling it locally. Last but not least, Carbon Capture systems can also be transposed to other applications, whether you could still apply the Direct Capture or you would need to install a separation unit before the purification process.

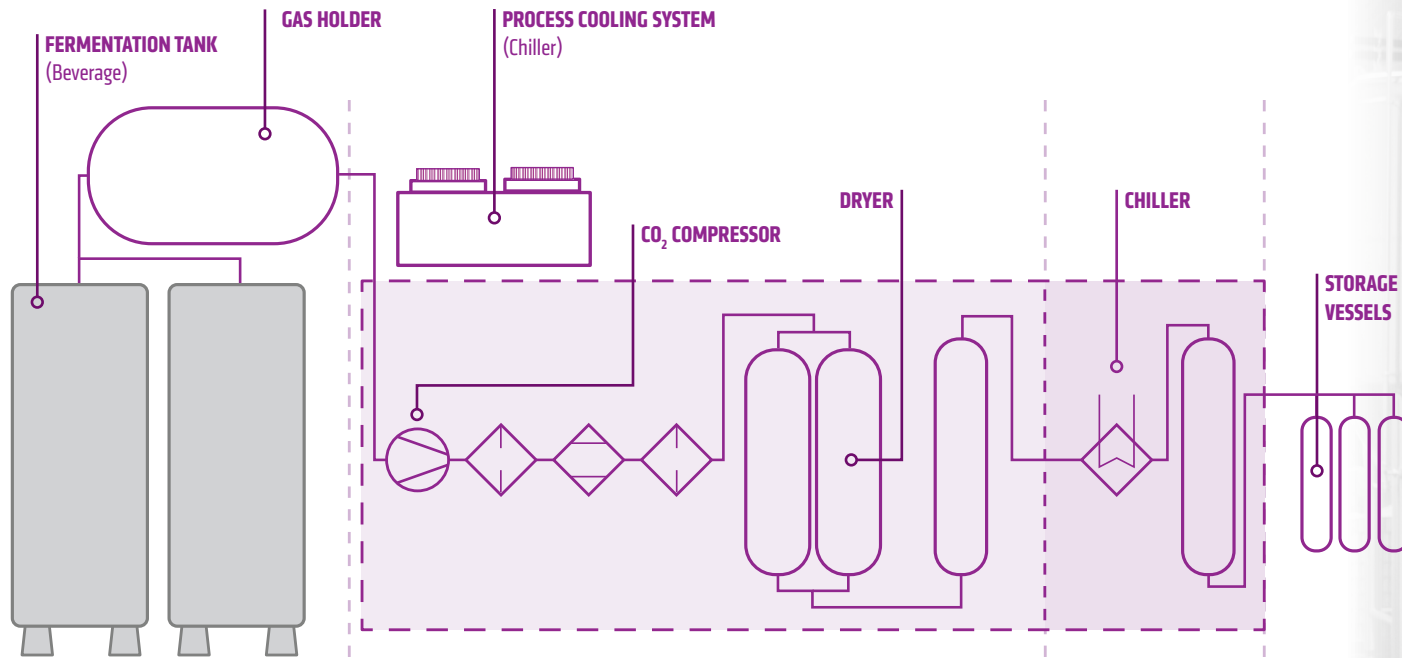

CAPTURE

Alcoholic fermentation is a biological process in which sugars are converted into energy in the form of adenosine triphosphate (ATP), producing ethanol and carbon dioxide (CO₂) as metabolic waste products. The CO₂ is gathered in a soft CO₂ buffer.

PURIFICATION

Used to create the best conditions (pressure, cleanliness and dew point) to enable later Liquefaction.

LIQUEFACTION

Liquid CO₂ is safer and easier to handle as compressed under high pressure.

STORAGE

CO₂ can be used on-site or sent elsewhere for further usage.



Gas dryers

CNG dryers He dryers



Process gas drying is a critical operation in many industries, including petrochemical, natural gas, and chemical manufacturing. The process involves removing moisture from gases used in manufacturing, processing, and transportation to prevent corrosion, maintain product quality, and ensure safe operations. This article explores the different types of process gas drying methods used in industry, their applications, and the benefits they offer.

Types of Process Gas Drying Methods

Adsorption

Adsorption is a commonly used process gas drying method that involves passing the gas through a bed of desiccant material. The desiccant material, which can be silica gel, activated alumina, or molecular sieves, adsorbs the moisture in the gas, leaving it dry. The desiccant material can be regenerated by heating it to a high temperature, which releases the moisture it has adsorbed. Adsorption is a highly efficient process gas drying method that can achieve very low dew points.

Refrigeration

Refrigeration is another common process gas drying method that uses a refrigeration unit to cool the gas below its dew point, causing the moisture in the gas to condense and form liquid droplets. The liquid droplets are then removed from the gas using a separator. Refrigeration is a highly effective process gas drying method that can achieve very low dew points.

Membrane Separation

Membrane separation is a process gas drying method that uses a semi-permeable membrane to remove moisture from the gas. The membrane allows the water molecules in the gas to pass through while preventing other gases from passing through. Membrane separation is a highly efficient process gas drying method that can achieve very low dew points.

Benefits of Process Gas Drying

Corrosion Prevention

Moisture in process gases can cause corrosion in pipelines and equipment, leading to costly repairs and downtime. Process gas drying helps prevent corrosion and maintain equipment integrity.

Product Quality

Moisture in process gases can also affect product quality. Process gas drying helps maintain product quality by ensuring that the process gases used in manufacturing are dry and free of contaminants.

Safe Operations

Moisture in process gases can create safety hazards, such as explosions and fires. Process gas drying helps ensure safe operations by removing moisture from process gases and reducing the risk of accidents.

Process gas drying is a critical operation in many industries, including petrochemical, natural gas, and chemical manufacturing. The process involves removing moisture from gases used in manufacturing, processing, and transportation to prevent corrosion, maintain product quality, and ensure safe operations. There are several types of process gas drying methods available, including adsorption, refrigeration, and membrane separation. Each method offers its unique benefits and is suitable for different applications. By choosing the right process gas drying method, industries can achieve cost savings, improved product quality, and safer operations.

CNG-DRY

Compressed natural gas dryers



Oper. pressure	0,1 - 420 bar
Capacity	on request
Dew point	-40 °C

He-DRY

Helium dryers



Oper. pressure	5 - 420 bar
Capacity	on request
Dew point	-25 °C to -70 °C

Compressed natural gas dryers (CNG dryers) are designed for continuous separation of water vapour from compressed natural gas thus lowering the dew point.

CNG-DRY dryers are normally custom made to meet specific project requirements. Several versions are available based on operating pressure and type of regeneration.

G-DRY type of the dryers are manual controlled and without regeneration. After the saturation of the dryer it is possible to replace adsorption material or regenerate it with external regeneration system.

CNG-R-DRY has two columns that operate alternately. Adsorption takes place under pressure in the first column while the second column is heat regenerated.

CNG-HP-DRY has also two columns that operate alternately. Regeneration is made by small portion of already dried CNG at the ambient pressure. Purge CNG is let to the suction side of the compressor.

Since Helium is an inert gas that has many similarities with air, it can therefore be used with our standard products to purify and dry it.

Since many industries can benefit from its unique properties to optimize their performance and productivity, to reduce labor costs and to make their operations safer, it is very important to determine in advance the technology which will best fit your Helium application.

He-A-B-F-DRY are different series of Low Pressure Heatless Regenerated Adsorption He Dryers

He-HP-DRY is a series of High Pressure Heatless Regenerated Adsorption He Dryers

He-R-DRY is a series of Low Pressure Heat Regenerated Adsorption He Dryers

He-HPR-DRY is a series of High Pressure Heat Regenerated Adsorption He Dryers



Gas purifiers

Hydrogen purifiers



Characteristics

The dihydrogen H_2 molecule, made up of two hydrogen atoms, is commonly called “hydrogen” and was discovered in 1766 by the British physicist Cavendish. Under normal conditions of temperature and pressure, hydrogen is a colorless and odorless gas but also the lightest element of the periodic table. It is soluble in water up to 1.6 mg/L at 21 °C.

It is the simplest member of the family of chemical elements and the most abundant one in the universe (main element of the Sun and stars). However, it is rarely found alone on and in the Earth, and is very often an integral part of various organic materials and, more importantly, water (H_2O).

Depending on its temperature and pressure, it can be found in different states: gaseous, liquid, solid, metallic and triatomic. Here, we will only concentrate on hydrogen in its gaseous state.

H2 Pure Units – Specifications

H2 Pure Units are designed for continuous separation of water vapour, oxygen and solid particles from hydrogen gas, making them eligible to all applications possible, including Fuel Cells (ISO 14687:2019). The unit is designed for fully automatic operation.

A proven and robust design enables efficient and reliable operation, fast installation and simple maintenance. The Purification Unit is suitable for easy integration in electrolyser hydrogen package. Version “P” consumes up to 2 % of hydrogen for regeneration while version “X” performs regeneration in closed loop meaning zero hydrogen is wasted during regeneration. Both versions are available with optional deoxo unit which reduces oxygen content down to <5 ppm.

Applications

The earliest known important chemical property of hydrogen is that it burns with oxygen to form water (H_2O), it was therefore made famous for its usage in the process of nuclear fusion. But it is now even more famous for its extremely low density, allowing it to be an energy vector to answer the problematic of electricity storage. Therefore Hydrogen is today widely considered as one of the key features that will play a major role in the world’s energy transition.

Hydrogen can be used for a variety of Industrial, Residential and Mobility applications:

- Chemical industry | Production of ammonia and other fertilizers (50% of global consumption)
- Petrochemical industry | Sulfur removal | Creation of gasoline and diesel (hydrocracking) | Methanol production (synthesis of amines and alkanes by hydrogenation)
- Food industry | Production of margarine and butter (fat hydrogenation)
- Welding | Atomic Hydrogen Welding (also called Plasma)
- Glass production | As antioxidant or shielding gas when coupled with nitrogen
- Electronics manufacturing | Production of semiconductors, LEDs, displays, etc
- Aerospace | Rocket’s engines (liquid form)
- Housing | Lighting, Heating
- Hydrogen Refueling Stations (HRS) for “Green Mobility” | Fuel Cells Electric Vehicles, FCEVs

POWER SOURCE
(Electricity)

The basis of every electrolysis plant is to have the insurance to receive constant power source (e.g. renewable for green hydrogen) and water supply.

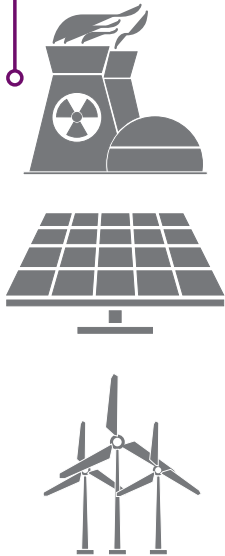

H2 Pure
Hydrogen purifiers



Oper. pressure	5 - 45 bar
Capacity	on request
Dew point	-25 °C to -70 °C

PURIFICATION MODULE IN ELECTROLYSIS PLANT

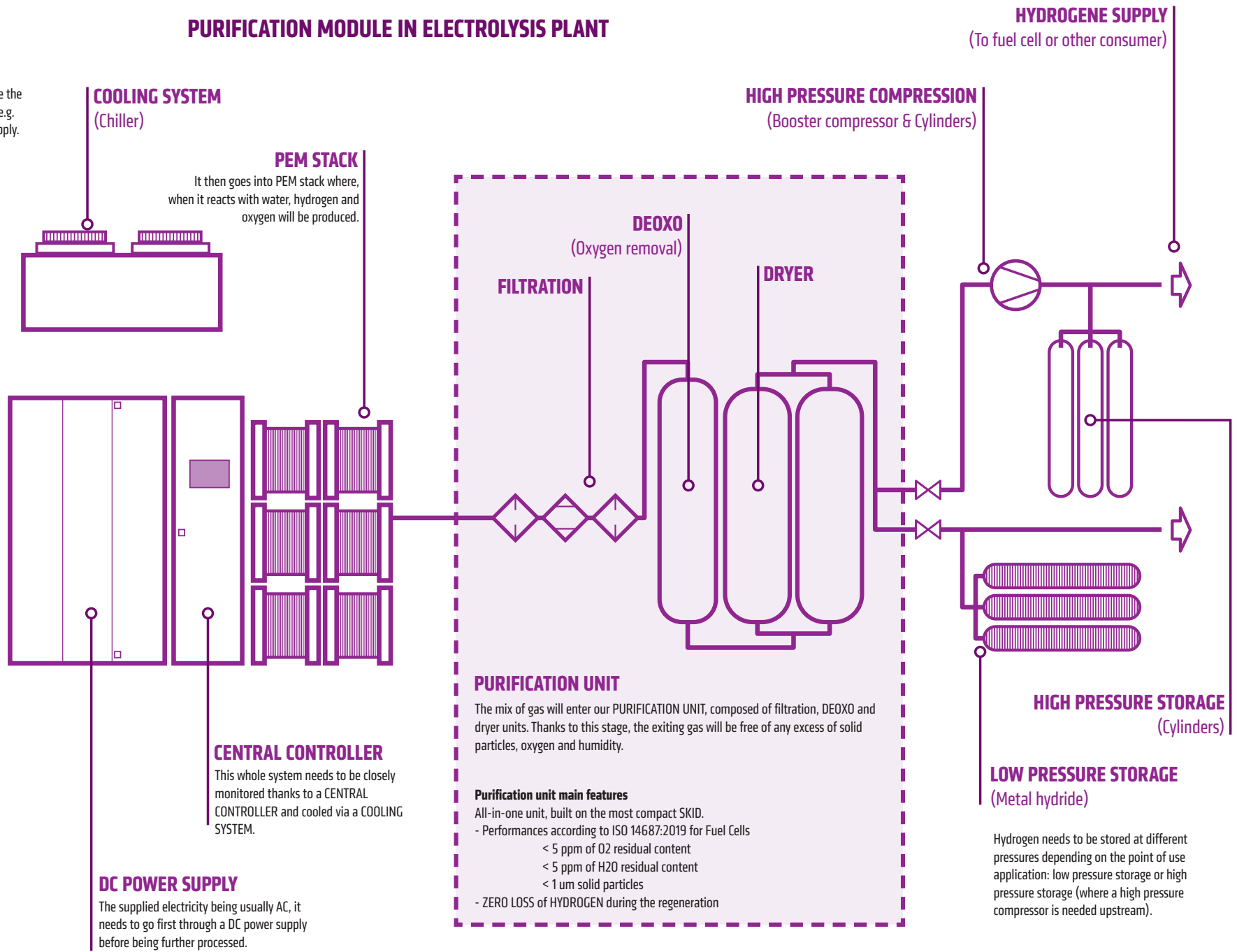

COOLING SYSTEM
(Chiller)

PEM STACK
It then goes into PEM stack where, when it reacts with water, hydrogen and oxygen will be produced.

CENTRAL CONTROLLER
This whole system needs to be closely monitored thanks to a CENTRAL CONTROLLER and cooled via a COOLING SYSTEM.

DC POWER SUPPLY
The supplied electricity being usually AC, it needs to go first through a DC power supply before being further processed.

PURIFICATION UNIT
The mix of gas will enter our PURIFICATION UNIT, composed of filtration, DEOXO and dryer units. Thanks to this stage, the exiting gas will be free of any excess of solid particles, oxygen and humidity.

- Purification unit main features**
- All-in-one unit, built on the most compact SKID.
 - Performances according to ISO 14687:2019 for Fuel Cells
 - < 5 ppm of O2 residual content
 - < 5 ppm of H2O residual content
 - < 1 um solid particles
 - ZERO LOSS of HYDROGEN during the regeneration

HYDROGENE SUPPLY
(To fuel cell or other consumer)

HIGH PRESSURE COMPRESSION
(Booster compressor & Cylinders)

HIGH PRESSURE STORAGE
(Cylinders)

LOW PRESSURE STORAGE
(Metal hydride)

Hydrogen needs to be stored at different pressures depending on the point of use application: low pressure storage or high pressure storage (where a high pressure compressor is needed upstream).

Industrial water chillers

Basics



Cooling types

- Direct cooling of a product
- Injection moulding of plastic
- Metal casting
- Metal machining

Applications

- Cooling of a process
- Fermentation of beer
- Fermentation of wine
- Chemical reactions
- Machine cooling
- Hydraulic circuit cooling
- Gearbox cooling
- Welding
- Laser cutting
- Metal treatment

Cooling in general

Industrial as well as commercial sector comprise many applications where cooling is required. Based on end application we differentiate:

- **PROCESS COOLING** when accurate and constant temperature within a process is required.

- **COMFORT COOLING** when accurate and constant temperature inside buildings is required.

Process cooling can further be described as removal of unwanted heat from a process. Quite often cooling liquid (e.g. water) is used for this purpose.

Industrial water chillers are devices that remove heat from a process or equipment using water as the cooling medium. They are commonly used in industrial applications, such as cooling machines and equipment, in manufacturing plants, and in the production of food and beverages.

The basic operation of an industrial water chiller involves the circulation of water through a heat exchanger that removes the heat generated by the process or equipment. The heat is then transferred to a refrigerant, which is compressed and condensed, releasing the heat to the surrounding environment.

The refrigerant is then expanded, which causes it to cool, and the process is repeated.

There are several types of industrial water chillers available, including air-cooled, water-cooled, and evaporative cooled chillers. The choice of chiller depends on various factors, such as the cooling capacity required, the ambient temperature, the availability of water, and the cost of electricity.

Industrial water chillers are an essential component in many industrial processes, as they help to maintain a consistent temperature and prevent equipment from overheating, which can result in costly downtime and repairs.

Process water circuit

Hot water from the process enters water tank where it is being cooled by the refrigerant circuit. Integrated water pump assures recirculation of the water.

Based on tank type we differentiate two versions:

- Closed type (pressurised system)
- Open type

OPEN TYPE WATER TANK

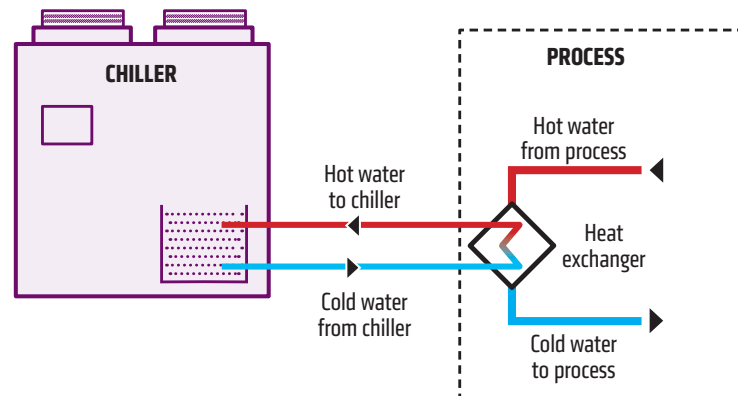

CLOSED TYPE WATER TANK

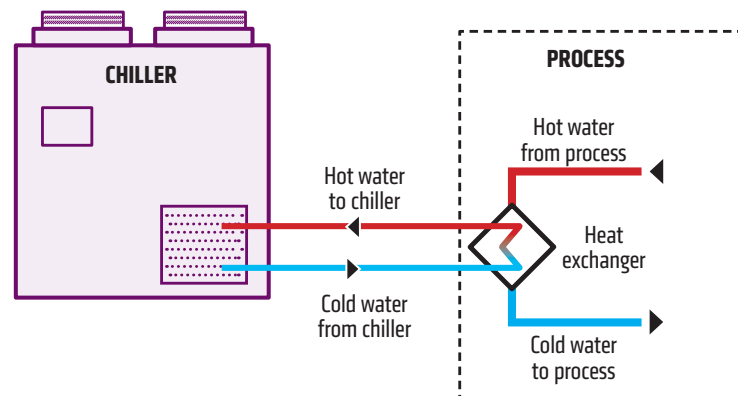

Industrial water chillers

Types



Operating principle

Operation of standard water chiller can be divided into two independent circuits:

Refrigeration circuit

Circulation of the refrigerant gas in the circuit is provided by highly efficient hermetically sealed compressor (4). Compressor rises the pressure of the gas which is then cooled down and liquified in the condenser (5). Electric fan on the condenser can be controlled by temperature or pressure sensor. Liquid refrigerant then flows through capillary tube or thermostatic expansion valve (8) which acts as a metering device to reduce the pressure of the refrigerant. Reduction of the pressure is a design function to achieve target temperature inside the evaporator (lower pressure = lower temperature). Filter (7) which is installed upstream the metering device intercepts impurities and assures reliable operation of the system. Liquid refrigerant is then guided through water tank where it is being evaporated by hy temperature of the process water (water gets cooled down). Low pressure refrigerant in gas form then re-enters the compressor.

PCI chillers operate based on “non-cycling” operating principle which means that when the chiller is without load “hot gas by-pass valve” (6) will release part of the hot refrigerant gas (from discharge side of the compressor) back to the suction side of the compressor. As a result evaporation pressure/temperature will be constant at the factory pre-set value. As an alternative the chiller can also be operated in ON/OFF operating mode.

In case of high discharge temperature controller stops the compressor before permanent damage occurs. Depending on size of the chiller additional safety/protection devices (e.g. low pressure switch, high pressure switch) are installed in on the refrigerant gas circuit.

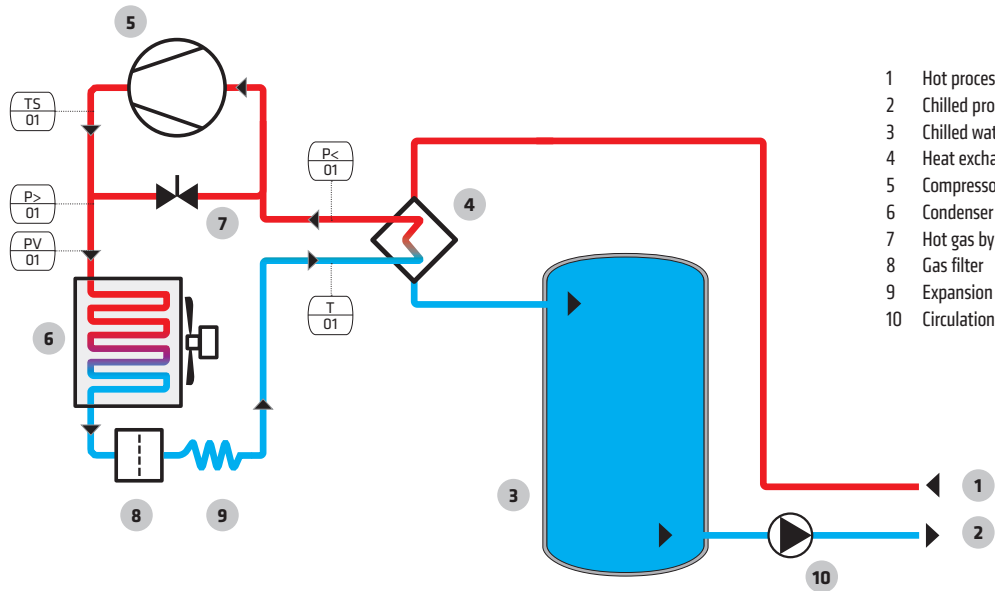

- 1 Hot process water inlet
- 2 Chilled process water outlet
- 3 Chilled water buffer
- 4 Heat exchanger module
- 5 Compressor
- 6 Condenser
- 7 Hot gas by-pass valve
- 8 Gas filter
- 9 Expansion valve or capillary tube
- 10 Circulation pump

PCI
Industrial process chillers



Cooling power: up to 150 kW
 Ambient temp.: up to +45°C
 Water outlet: down to 5°C (-5°C glycol)



Pressure vessels

Basics

Compressed air receiver

A compressed air receiver is an essential part of every compressed air system. Air receivers are tanks used for compressed air storage and are recommended to be in all compressed air systems. But they are not just vessels, they serve several important purposes:

- Eliminate pulsations from the discharge line.
- Decrease wear and tear on the compression module, control system and motor by reducing excessive compressor cycling.
- Help reduce dew point and temperature spikes that follow regeneration.
- Separate moisture oil and solid particles provide extra storage for compensating surges in compressed air usage.
- Reduce energy costs associated with excessive starting of the compressor motor.

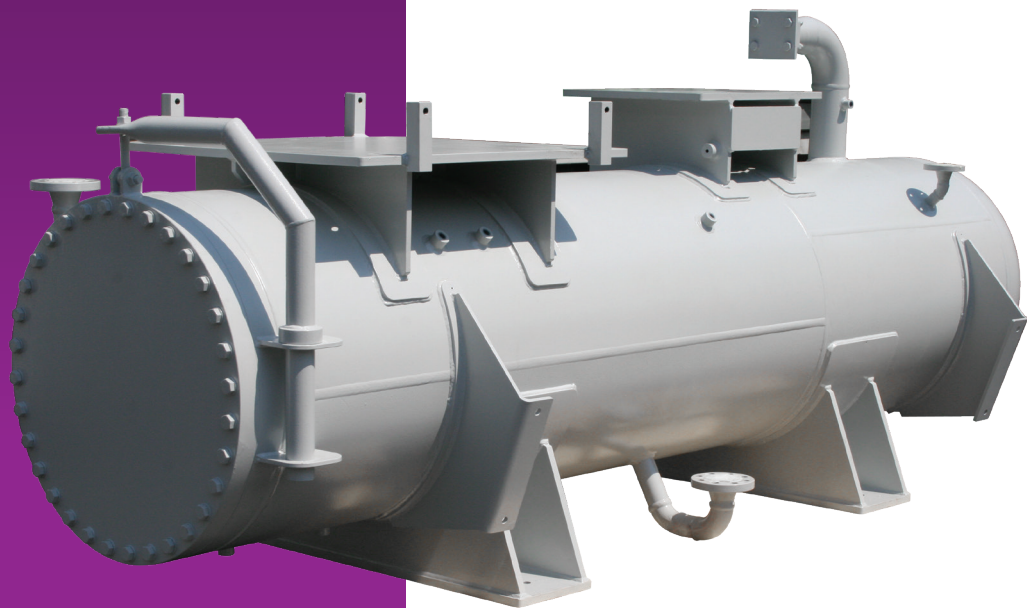

Air receiver equipment

Air could be dangerous in compressed stage because of accumulated energy. Therefore compressed air receivers must be equipped with a pressure safety valve, this is a device, which releases the compressed air from the receiver into the environment in case of excessive pressure. When the set pressure is exceeded, the pressure safety valve becomes the “path of least resistance” as the valve is forced open and a portion of the fluid is diverted through the auxiliary route. The pressure safety valve is designed or set to open at a predetermined pressure setting to protect pressure vessels and other equipment from being subjected to pressures that exceed their design limits. All safety valves should be tested frequently and at regular intervals to determine whether they are in good operating condition. No valve of any type should be placed between the air receiver and its safety valve or valves.

Air receivers have a drain valve to eliminate accumulated moisture. A drain pipe and valve should be installed at the lowest point of every air receiver to provide for the removal of accumulated oil and water. Adequate automatic traps may be installed in addition to drain valves. The drain valve on the air receiver must be opened and the receiver completely drained frequently and at such intervals as to prevent the accumulation of excessive amounts of liquid in the receiver.

They also have pressure gauges (installed in visible locations), handholes or manholes, and a base for vertical air receivers. Standard receivers are designed for horizontal or vertical mounting.

Manufacture

There is extreme danger in the use of air receivers of unsound or questionable construction. In the interest of safety, it is essential that the air receivers are manufactured strictly in accordance with a reputable engineering standard or code.

All welds should be carried out by welders who have been tested to the relevant National Code. All the materials used in the manufacture of the receivers must comply with the requirements of the relevant design code, and be identifiable with mill sheets.

Design

There are many engineering standards which give information on the design, construction and fittings of an air receiver. Pressure vessels are loaded with internal pressure, for this reason, their operation is potentially hazardous. Their manufacture, testing, installation and operation must be carried out in accordance with the European Pressure Equipment Directive (PED) or other standards (ASME, DNV...).

The content of the directive is changing, therefore it is necessary to continuously follow to possible variations. Documentation of the pressure vessel should be carefully kept. Pressure vessels must always bear a data plate with the content required by the Pressure Equipment Directive.

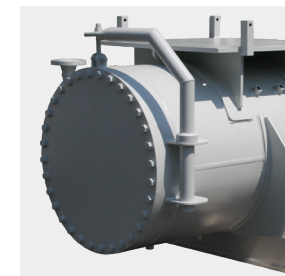

Installation

There is always a question of where to install the air receiver in the compressed air system. This decision depends on what function it is meant to perform. It can serve for several different purposes:

- Dampening of compressor pulsation
- Air flow buffering
- Air cooling
- Collection and draining of oil and water
- Storage of wet air before a dryer
- Storage of dry air after a dryer

Air receiver must be protected against external damage, for example, against falling objects. It must be installed in such manner, that access to all receiver components is easy, undisturbed and safe. The pressure vessel must be positioned securely and reliably, and should not be moved or tilted. Observe the additional load due to the pressure of the air inside. Integrated data plate must be easily visible. The pressure vessel must be protected against corrosion and harmful atmospheric conditions.

Safety requirements

Air in compressed stage could be dangerous because of accumulated energy. Therefore, it is necessary to strictly observe the safety criteria for safe operation of the system.

Safety measures include the following equipment and precautions:

- A pressure vessel must be equipped with a suitable spring-loaded safety valve, which prevents exceeding its maximum allowable operating pressure.
- Suitable pressure gauge must be fitted to the pressure vessel to indicate current pressure.
- Suitable condensate drain device must be fitted to the lowest bottom connection of the pressure vessel.
- It must be provided with suitable manhole, handhole or other means to allow the interior to be thoroughly inspected and cleaned.
- It must be clearly marked with the maximum permissible working pressure and temperature.
- Suitable shut-off valves with appropriate pressure level should be fitted on upstream and downstream connections to isolate the pressure vessel from the other system.

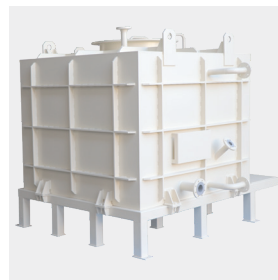
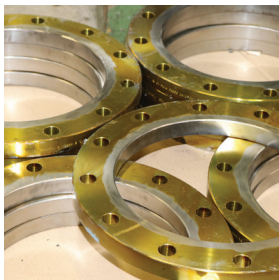

Pressure vessels

Types



MATERIALS
Carbon steel
Stainless steel

DESIGN LIMITS	
Volume	0,1 to 75 m ³
Length	10 m
Diameter	3 m
Mass	12 T (22 T)
Shell thickness	30 mm

DESIGN CODES / CERTIFICATES

STANDARD

- Directive 2014/68/EU PED Pressure Equipment

OPTION

- ASME "U" Designator (The American Society of Mechanical Engineers (section VIII div. 1)
- ASME "UM"
- CRN Canadian Registration Number
- EAC - REGULATIONS Customs Union "On the safety equipment of high pressure" (TR TC 032/2013)
- EAC - REGULATIONS Customs Union "On the safety on machines and equipment" (TR CU 010/2011)
- DGM / DPP Algeria (ex ARH)
- UKR Ukraine
- JBA Japan boiler Association approval
- AS 1210 Australian Standard
- MOM Singapore
- NR13 Brazil
- Serbia AAA
- ABS American Bureau of Shipping
- DNV

PRESSURE VESSELS		Pressure
PV PED	Pressure vessels according to PED certification	11 bar
HPV PED	High pressure vessels according to PED certification	16, 21, 32, 42, 48 bar
CUSTOM MADE PV	Pressure vessels according to customer specification	on request

Compressed air receiver is an essential part of every compressed air system. It acts as a buffer and a storage medium between the compressor and the consumption system.

Air receivers are much more than just buffers. Their purpose is also:

- reducing excessive compressor cycling,
- eliminating pulsations from discharge line,
- collecting condensate and water in the air after the compressor,
- reducing energy costs by minimizing excessive starting of the compressor motor,
- help reducing dew point and temperature spikes...

Omega Air d.o.o is also a producer of custom made pressure vessels according to PED, ASME and other standards. Each of our pressure vessels is calculated, assembled, tested and guaranteed to conform standards and to withstand the process necessary for your application.

Custom made pressure vessels can include a diverse range of:

- sizes and volumes,
- horizontal or vertical designs,
- modular or packaged systems,
- special alloys and materials,
- high or low pressure ratings,
- heating and cooling options,
- accessory valves and piping,
- ladders and platforms,
- anticorrosion protection...

PV PED

Pressure vessels according to PED certification



Oper. pressure 11 bar

HPV PED

High pressure vessels according to PED certification



Oper. pressure 11, 21, 32, 48 bar

CUSTOM PV

Pressure vessels according to customer specifications



Oper. pressure on request



Measuring equipment

Basics

Compressed air is one of the most common but also one of the most expensive energy sources in industry. Quality and energy efficient air compressors are definitely the most important components of every compressed air system, but without appropriate air treatment and measuring equipment it is not possible to provide quality and low cost compressed air. Stable product quality, process optimization and energy savings are just some of the reasons why measuring equipment is becoming essential part of today's compressed air/gas systems.

Measuring compressed air properties and characteristics is important for several reasons:

Efficiency

Measuring compressed air properties such as pressure, flow rate, and temperature can help ensure that the system is running at peak efficiency. This can help reduce energy costs and increase productivity.

Safety

Compressed air systems can be dangerous if not properly maintained and monitored. Measuring properties such as moisture content and oil content can help identify potential safety hazards and prevent accidents.

Quality control

Measuring compressed air properties can help ensure that the air is clean and dry, which is important for applications such as food and beverage production, pharmaceutical manufacturing, and electronics manufacturing.

Maintenance

Measuring properties such as air quality and pressure can help identify potential issues before they become major problems, allowing for timely maintenance and repair.

Compliance

Certain industries, such as food and beverage and pharmaceuticals, have strict regulations regarding air quality. Measuring compressed air properties can help ensure that the air meets these regulatory requirements.

Cost savings

Measuring compressed air properties can help identify leaks and inefficiencies in the system. By addressing these issues, energy costs can be reduced and overall system efficiency can be improved.

Equipment protection

Measuring properties such as humidity and dew point can help prevent damage to equipment from moisture and corrosion.

Process control

Measuring compressed air properties can help ensure that the air is suitable for specific applications, such as controlling the consistency of paint or coatings.

Overall, measuring compressed air properties and characteristics is important for a variety of reasons, including efficiency, safety, quality control, maintenance, compliance, cost savings, equipment protection, and process control.

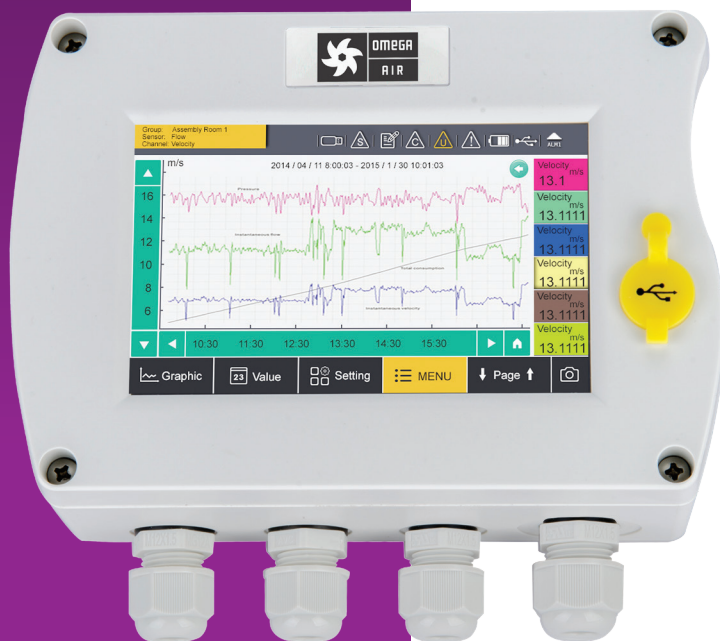



DISPLAY / DATA LOGGER

Measuring means knowing the actual performance of your system and our display units/data loggers provide a user friendly and cost effective solution for monitoring of different operating parameters (pressure, flow, dew point, ...). Number and type of input signals, as well as analytics capability depend on the version of display/data logger unit used.



PRESSURE SENSOR

Operating pressure is one of the most important parameters of any compressed air/gas system. Precise measurement of pressure is vital for most stages of air treatment (e.g. filters, dryers, ...) as well as for applications at consumption side (e.g. machines, end-users, ...). Indirect pressure sensors can also give us information about energy losses through pressure drop.



DEW POINT SENSOR

In order to provide stable product quality, contaminants including water must be removed or reduced to the acceptable level based on specific application requirements. Humidity (water vapour content) is expressed in the terms of Pressure Dew Point (PDP) where dew point is the temperature at which air is 100 % saturated with moisture. Dew point sensor gives us reliable information about actual PDP of compressed air and makes it possible to react quick in case PDP is out of limit.



FLOW / CONSUMPTION SENSOR

Flow measurement is essential part of every compressed air/gas system. By knowing the exact air production or consumption rate, we can optimize complete system, assure stable quality and also reduce energy losses. Flow monitoring of existing system also gives us valuable information in case we are dimensioning a new system or considering an upgrade to the system.



RESIDUAL OIL SENSOR

Oil presence in compressed air has negative effect on most air treatment applications (PSA systems, membranes, ...) as well as on end product/process quality and safety. Therefore it is essential that oil content does not exceed permissible value. Proper air treatment equipment reduces oil content but only the use of a proper residual oil sensor and sufficient monitoring assures that air quality meets requirements of specific application. Sensor with PID (photoionization detector) offers an easy to use, affordable and reliable solution.



LASER PARTICLE COUNTER

Dust and particle elimination through increasingly fine levels of filtration is common throughout the compressor plant. But even then further contamination throughout the distribution system can occur, which makes point of use filtration and measurement essential for maintaining compliance with plant or international standards. Monitoring the particle sizes and concentration is a key indicator of the system's efficiency that can be used to guide maintenance tasks, as well as contribute to plant compliance with the purity classes set in ISO 8573-1.



Measuring equipment

Types



INSTRUMENTS DE MESURE

OS 331	Afficheur/enregistreur de données
OS 401	Capteur de débit massique thermique
OS 421	Capteur de débit massique thermique
OS 415	Capteur de débit massique thermique
OS 430	Capteur de débit à tube de Pitot
OS 211, OS 215, OS 220	Capteurs de point de rosée
OS 305	Moniteur de point de rosée
OS 520	Capteur de point de rosée portable
OS 16, OS 40	Capteurs de pression
OS 531	Détecteur de fuite portable à ultrasons
OS 120	Capteur d'huile résiduelle
OS 130, OS 132	Compteur de particules laser
OS 600 set	Analyseur de pureté d'air comprimé portable
OS 601	Analyseur de pureté d'air comprimé portable
OS 551-P4 set	Enregistreur de données portable (débit, point de rosée, pression)
OS 551-P6 set	Enregistreur de données portable (débit, point de rosée, pression)

OS 331

Display and Data logger



OS 401

Thermal mass flow sensor



OS 421

Thermal mass flow sensor



OS 415

Thermal mass flow sensor



OS 430

Pitot tube flow sensor



OS 211, OS 215, OS 220

Dew point sensors



OS 305

Dew point monitor



OS 520

Portable dew point sensor



OS 16, OS 40

Pressure sensor



OS 531

Portable ultrasonic leak detector



OS 120

Residual oil sensor



OS 130, OS 132

Laser particle counter



OS 600 set

Portable compressed air purity analyser



OS 601

Portable compressed air purity analyser



OS 551-P4 set

Portable data logger, flow, dew point, pressure sensors



OS 551-P6 set

Portable data logger, flow, dew point, pressure sensors



Compressed air additional program

Products



Compressed air is a versatile form of energy that can be used for a wide variety of applications, from powering tools and machinery to providing clean breathing air in hazardous environments. To maximize the benefits of compressed air, additional equipment can be added to the system to enhance performance, efficiency, and safety.

Heat Regeneration Units

Compressed air systems generate a lot of heat during operation, which can be wasteful and expensive. Heat regeneration units can help recover some of that energy by transferring the heat from the compressed air to water or other fluids. This can be used to preheat water for industrial processes or for space heating, which can result in significant energy savings.

Breathing Air Equipment

Compressed air is often used to provide clean breathing air in hazardous environments, such as in mining, firefighting, and industrial settings. Breathing air equipment, such as air compressors and filters, are used to ensure that the air is free of contaminants, such as dust, oil, and moisture. This is crucial for the safety and health of workers who need to breathe in such environments.

Painting Air Filters

When compressed air is used for painting or other finishing applications, it is important to remove any impurities that could mar the surface finish. Painting air filters remove moisture, oil, and other contaminants from the compressed air, ensuring a clean and smooth finish.

Compressors for Petrol Stations

Compressed air is also used in petrol stations to power air compressors for filling tires and other automotive components. These compressors need to be robust and reliable, with the ability to deliver compressed air at high pressure quickly and efficiently.

In conclusion, compressed air systems can benefit from a range of additional equipment that can improve performance, efficiency, and safety. Heat regeneration units, breathing air equipment, painting air filters, compressors for petrol stations, air dryers, air filters, and air receivers are just some of the options available to optimize compressed air systems. By investing in the right equipment, users can maximize the benefits of compressed air and ensure a safe and reliable system for years to come.

COMPRESSED AIR EQUIPMENT		Pressure	Capacity
PP	Painting air filtration systems	16 bar	78 - 120 Nm ³ /h
B-AIR	Breathing air filtration systems	16 bar	78 - 780 Nm ³ /h
B-AIR plus	Portable breathing air filtration system	16 bar	120 Nm ³ /h
AIRWATT	Heat recovery units	16 bar	
BS 12-3,5	Petrol station equipment	12 bar	350 NI/h
AWS	Petrol station equipment	10 bar	170 NI/h
PETRO-PACK	Petrol station equipment	12 bar	350 NI/h
BS TOWER	Petrol station equipment	12 bar	

PP
Painting air filtration systems



Oper. pressure 16 bar

B-AIR
Breathing air filtration systems



Oper. pressure 16 bar

B-AIR plus
Portable breathing air filtration systems



Oper. pressure 16 bar

AIRWATT
Heat recovery units



Oper. pressure 16 bar

BS 12-3,5
Petrol station equipment



Oper. pressure 12 bar

AWS
Petrol station equipment



Oper. pressure 10 bar

PETRO-PACK
Petrol station equipment



Oper. pressure 12 bar

BS TOWER
Petrol station equipment



Oper. pressure 12 bar

ES
Exhaust silencers



Oper. pressure 16 bar

FA
Flange adapter

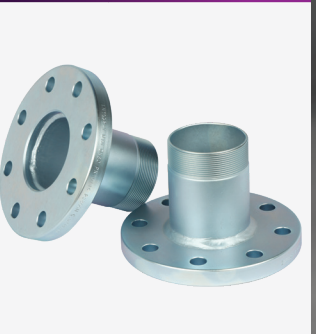

Oper. pressure 16 bar, 63 bar



Industrial engineering

From design to the end product

We have the knowledge and the solution

We guarantee you reliable problem management and finding simple but effective solutions for your system. With our rich knowledge and experience in the domestic and global markets, we have improved the energy of a huge number of systems, built energetically and economically efficient solutions, and helped eliminate many technical problems. Proof of this is our loyal and satisfied customers.



We know how and we can produce

We are convinced that it is best if we face the problems ourselves. Therefore, almost all production processes for system components are carried out in our factories, and most of the components are also the result of our knowledge and development and are created in our production. We are experts with globally recognized quality.



Your needs - our challenge

We like challenges that encourage us to find innovative solutions. Surely there is an expert among us who knows the answer to even such a difficult technical question. Over 30 of our development engineers and technicians from various branches of industry will look for solutions to reduce your costs and make the system economically efficient. There are no obstacles! We have helped many, so can you.

Transportation is taken care of

Transporting the delivered system to the place of installation is the concern of our logistics department.



Maintenance - our responsibility

In order for your system to be ready for reliable operation, the system will be commissioned by our engineers, who will also provide a warranty for the installed components. Our service will ensure good maintenance and operation of your system for many years after installation. To make your work easier, you can also opt for contractual maintenance.



Assembly as it should be

The entire supplied system will be installed by experienced specialists for the implementation of hardware installations. For works that we cannot carry out ourselves, we cooperate with verified quality subcontractors. Worrying about the quality of installation is completely unnecessary.



SKID and BOX UNITS

All our knowledge integrated in one product

SKID units

Skid based compressed air/gas supply system is a compact unit intended to generate and supply compressed air, nitrogen or oxygen according to specific project requirements. Robust frame is optimised for safe and fast movement. Skids are available in variety of configurations based on capacity, type and quality of air/gas.

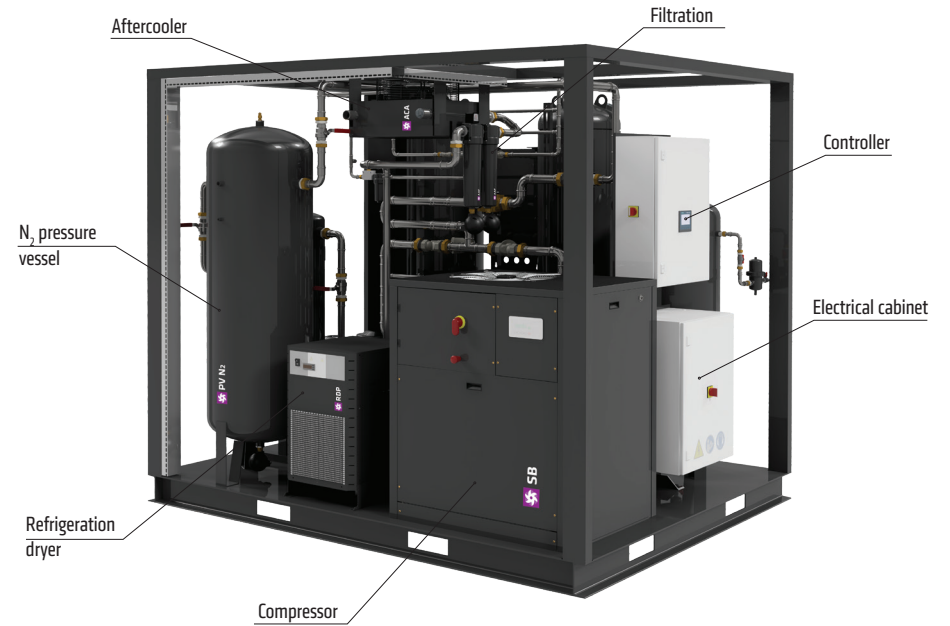

N₂ SKID units - components



Professional selection

Correct sizing

Professional installation

Modularity

Small size

Saving time and money

Compactness

Saving space

Flexibility

Outdoor installation (BOX)

**CONTAINERS
AND
SKIDS**

System tested before dispatching

Plug and play units

CONTAINER units

Container units are used for outdoor installation. Such systems are completely independent and protected from the weather conditions, and are characterized by high mobility, as they can be easily moved to a new location.

N₂ BOX units - components



SKID and BOX UNITS

Types

STANDARD UNITS

Our industrial engineering division is able to integrate standard or custom made products into a skid/ container based package according to specific project requirements. SKID and BOX units can be designed according to variety of design codes (PED, ASME, DNV, ABS, NR13, AS1210 ...).

All we need is the following information from you:

- type of gas
- flow range
- pressure range
- temperature range
- min. solids content
- min. moisture content
- min. oil content

Based on this, our engineers will determine the components of the system and combine them into a unique unit with reliable supply of constant output gas parameters for your production process.

Air+

Air station

Air+ is the label for our high-quality compressed air units in accordance with ISO 8573-1. These units represent complete air treatment for your system and can be integrated into a compact unit with constant and stable outlet parameters, that ensure reliable production of compressed air for your process.

Air+ units basically contain the following components:

- compressor(s)
- compressed air filtration
- moisture separation
- compressed air drying
- water/oil separation...

Compressed air at the outlet of the unit reaches and maintains the parameters, required by the customer when ordering.

The unit is compact and mobile and contains everything for the normal operation of your process.

The system can be integrated into a SKID or BOX unit.

Class	SOLID PARTICLES		
	Maximum number of particles per cubic meter as a function of particle size, d ⁽²⁾		
	0,1µm < d ≤ 0,5µm	0,5µm < d ≤ 1,0µm	1,0µm < d ≤ 5,0µm
0	As specified by the equipment user or supplier and more stringent than class 1		
1	≤ 20.000	≤ 400	≤ 10
2	≤ 400.000	≤ 6.000	≤ 100
3	Not specified	≤ 90.000	≤ 1.000
4	Not specified	Not specified	≤ 10.000
5	Not specified	Not specified	≤ 100.000
6			

Class	HUMIDITY AND LIQUID WATER		OIL	
	Pressure dew point		Concentration of total oil ⁽²⁾ (liquid, aerosol and vapour)	
	°C	°F	mg/m ³	ppm/w/w
0				
1	≤ -70	-94	≤ 0,01	≤ 0,008
2	≤ -40	-40	≤ 0,1	≤ 0,08
3	≤ -20	-4	≤ 1	≤ 0,8
4	≤ +3	38	≤ 5	≤ 4
5	≤ +7	45	Not specified	Not specified
6	≤ ±10	50		

⁽¹⁾ To qualify for a class designation, each size range and particle number within a class shall be met. ⁽²⁾ At reference conditions: air temperature of 20° C, absolute air pressure of 100 kPa (1 bar), 0 relative water vapour pressure.





Oxygen station

O₂SKID or **O₂BOX** are oxygen production systems. They are basically the Air⁺ compressed air preparation unit with built-in oxygen production components.

O₂ unit consists of:

Air⁺ components:

- compressor(s)
- compressed air filtration
- moisture separation
- compressed air drying
- water/oil separation...

+

O₂ production components:

- activated carbon tower
- oxygen PSA generator

Oxygen station can produce oxygen at various ranges of purities. Normally, the purity of oxygen produced by PSA is from 90% to 95%.

Field of use	Purity of the oxygen
Metal production, welding, cutting	95 %
Glass production	95 %
Fish farms	90 % to 95 %
Healthcare, veterinary medicine	95 %
Ozone generators	90 % to 95 %
Waste water treatment plants	90 % to 95 %



Nitrogen station

N₂SKID or **N₂BOX** are nitrogen production systems. They are basically the Air⁺ compressed air preparation unit with built-in nitrogen production components.

N₂ unit consists of:

Air⁺ components:

- compressor(s)
- compressed air filtration
- moisture separation
- compressed air drying
- water/oil separation...

+

N₂ production components:

- activated carbon tower
- nitrogen PSA generator

Nitrogen station can produce nitrogen at various range of purities. Normal nitrogen purity for food processing is in the range from 99% to 99,5%. Lower purity nitrogen in the range from 96% to 99% is often used in fire and explosion prevention. High purity with nitrogen content from 99,9 % to 99,999 % is typically used for laser cutting, electronics soldering and pharmaceutical applications.

Field of use	Purity of the N ₂
Food processing: - Wine blanketing - Beer dispense - Oil sparging - Fruit storage	99,0 % to 99,9 %
Fire prevention	95 %
Explosion prevention	98% to 95 %
Chemical blanketing	99 % to 95 %
Pressure testing	95 %
Injection molding	99 % to 99,5 %
Electronic soldering	99,95 % to 99,995 %
Laser cutting	99,95 % to 99,995 %
Pharmaceutical	99,95 to 99,999 %



Projects

Industrial project engineering is a specialized field that involves designing, developing, and implementing complex systems and custom-made solutions for various industries. These solutions are tailored to meet the specific needs of each client and can range from large-scale industrial plants to smaller, more focused systems. In this article, we will explore the importance of industrial project engineering and the key components of a successful project.

Industrial project engineering is a critical component of modern manufacturing and production processes. The success of a project depends on the ability of the engineering team to design, develop, and implement a system that meets the client's requirements, while also complying with safety and regulatory standards.

A well-executed industrial project can result in increased efficiency, productivity, and profitability for the client. It can also improve the quality of the end product, reduce waste, and minimize environmental impact. A successful project can also enhance the reputation of the client, as well as the engineering team responsible for the project.

Key Components of a Successful Industrial Project

Design and Planning: The design and planning phase is critical to the success of an industrial project. It involves gathering information about the client's requirements, analyzing data, and developing a comprehensive plan that outlines the scope, timeline, and budget of the project. This phase also involves identifying potential risks and developing strategies to mitigate them.

Engineering

The engineering phase involves developing detailed designs, drawings, and specifications for the system. This phase also includes selecting the appropriate materials, equipment, and technologies needed to implement the project.

Fabrication and Assembly

The fabrication and assembly phase involves the construction and assembly of the system. This phase includes procuring the necessary materials and equipment, as well as managing the construction process to ensure that the project is completed on time and within budget.

Testing and Commissioning

The testing and commissioning phase involves testing the system to ensure that it operates as intended. This phase includes conducting performance tests, troubleshooting any issues, and ensuring that the system meets all safety and regulatory requirements.

Maintenance and Support

The maintenance and support phase involves providing ongoing support to the client to ensure that the system operates at peak performance. This includes providing training to personnel, conducting regular maintenance, and troubleshooting any issues that arise.

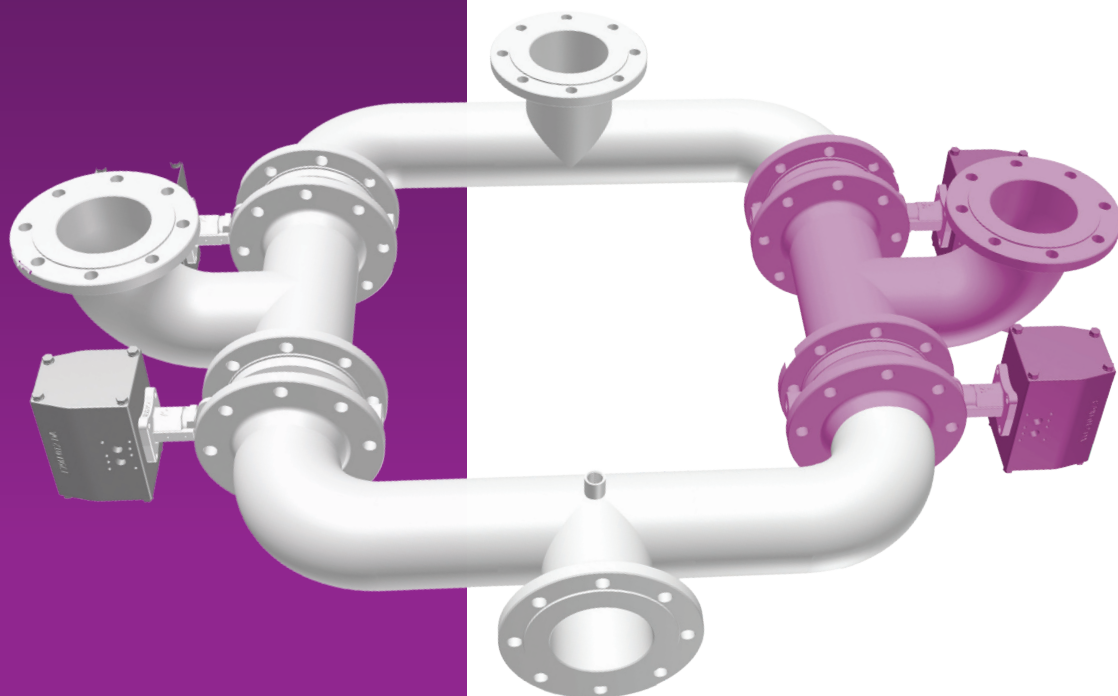

SPECIAL PROJECTS

Compressed air stations	Custom made compressed air stations
Special designed SKID units	Custom made SKID units
Special designed BOX units	Custom made BOX units
CCS	Carbon capture systems

COMPRESSED AIR STATIONS

Custom made compressed air stations



SKID UNITS

Custom made SKID units



BOX UNITS

Custom made BOX units



CCS

Carbon capture systems

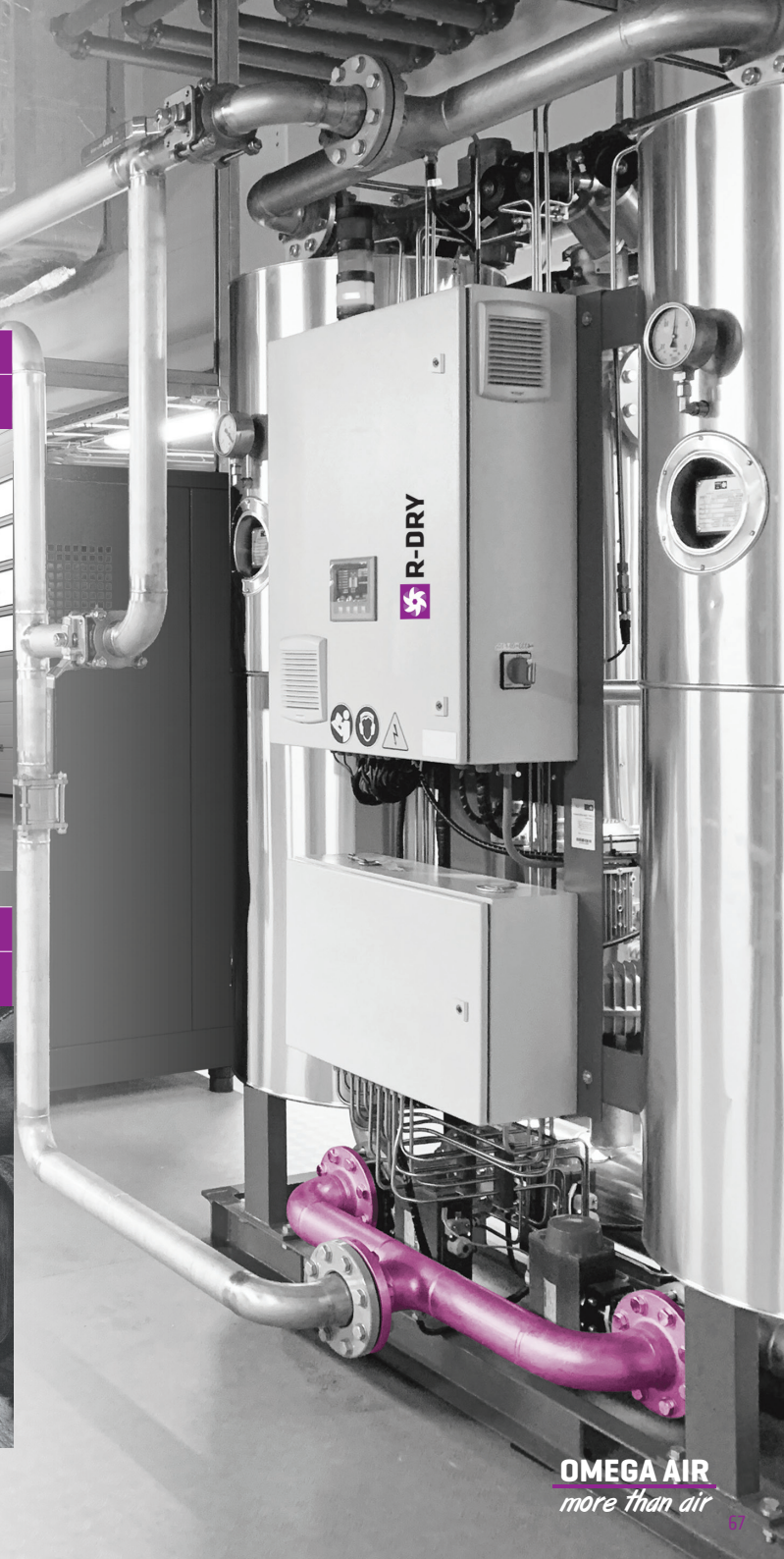
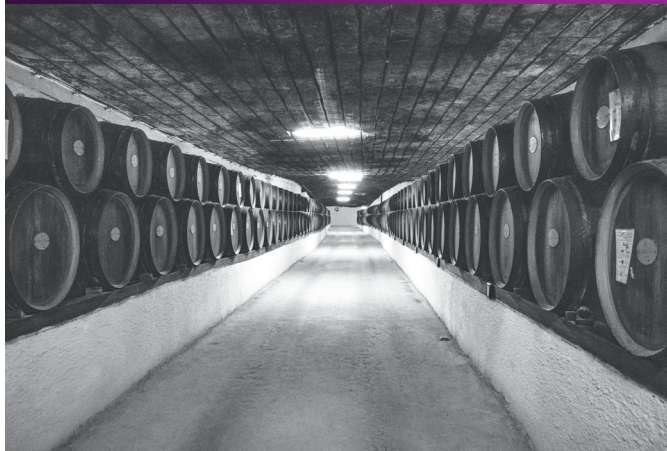

AirSys

Product selection software

The AirSys is selection software designed by Omega Air.

It is being developed for fast and user friendly selection of Omega Air products.

The AirSys software provides suggestions for components which enables the user to select the best suited component based on several deciding parameters such as operating pressure, operating temperature, flow capacities...

With AirSys you can easily select proper filters, filter elements, drains, dryers etc.



Airsys v "0.12"

- Filters
- Dryers
- Generators
- Carbon towers
- Condensate
- Heat recovery units
- Toolbox
- Stock
- About

OMEGA AIR
Air and Gas

Logout

- Filters
- Dryers
 - Refrigeration Dryer
 - Adsorption Dryer
 - Membrane Dryer
- Generators
- Carbon towers
- Condensate
- Heat recovery units
- Toolbox
- Stock
- About

Adsorption dryers selection

Inlet air flow	<input type="text" value="3000"/>	<input type="text" value="m³/h"/>	▼
Inlet pressure	<input type="text" value="7"/>	<input type="text" value="bar"/>	▼
Inlet air temperature	<input type="text" value="85"/>	<input type="text" value="°C"/>	▼
Inlet pressure dew-point	<input type="text" value="85"/>	<input type="text" value="°C"/>	▼
Outlet pressure dew-point	<input type="text" value="-40"/>	<input type="text" value="°C"/>	▼
Ambient temperature	<input type="text" value="25"/>	<input type="text" value="°C"/>	▼
Ambient relative humidity	<input type="text" value="50"/>	<input type="text" value="%"/>	▼
Regeneration type	<input type="text" value="Heatless regenerated"/>		
<input type="button" value="Search"/>			



Recommended

Nominal air flow	<input type="text" value="3000"/>	<input type="text" value="m³/h"/>	▼
Nominal pressure	<input type="text" value="7"/>	<input type="text" value="bar"/>	▼
Nominal pdp	<input type="text" value="-40"/>	<input type="text" value="°C"/>	▼
Max. flow	<input type="text" value="3000"/>	<input type="text" value="m³/h"/>	▼
Pressure	<input type="text" value="4 - 16"/>	<input type="text" value="bar"/>	▼
Ambient temperature	<input type="text" value="1,5 - 60"/>	<input type="text" value="°C"/>	▼
Inlet temperature	<input type="text" value="1,5 - 60"/>	<input type="text" value="°C"/>	▼
Purge	<input type="text" value="593,23"/>	<input type="text" value="m³/h"/>	▼
	<input type="text" value="19,441"/>	<input type="text" value="%"/>	▼
Regeneration type	<input type="text" value="Standard"/>		
Avg. air consumption	<input type="text" value="466,584"/>	<input type="text" value="m³/h"/>	▼
	<input type="text" value="15,593"/>	<input type="text" value="%"/>	▼
Outlet air flow	<input type="text" value="2593,416"/>	<input type="text" value="m³/h"/>	▼
Width	<input type="text" value="1120"/>	<input type="text" value="mm"/>	▼
Height	<input type="text" value="2400"/>	<input type="text" value="mm"/>	▼
Length	<input type="text" value="1875"/>	<input type="text" value="mm"/>	▼
Mass	<input type="text" value="1850"/>	<input type="text" value="kg"/>	▼



Manual

Nominal air flow	<input type="text" value="3000"/>	<input type="text" value="m³/h"/>	▼
Nominal pressure	<input type="text" value="7"/>	<input type="text" value="bar"/>	▼
Nominal pdp	<input type="text" value="-40"/>	<input type="text" value="°C"/>	▼
Max. flow	<input type="text" value="3000"/>	<input type="text" value="m³/h"/>	▼
Pressure	<input type="text" value="4 - 16"/>	<input type="text" value="bar"/>	▼
Ambient temperature	<input type="text" value="1,5 - 60"/>	<input type="text" value="°C"/>	▼
Inlet temperature	<input type="text" value="1,5 - 60"/>	<input type="text" value="°C"/>	▼
Purge	<input type="text" value="593,23"/>	<input type="text" value="m³/h"/>	▼
	<input type="text" value="19,441"/>	<input type="text" value="%"/>	▼
Regeneration type	<input type="text" value="Standard"/>		
Avg. air consumption	<input type="text" value="466,584"/>	<input type="text" value="m³/h"/>	▼
	<input type="text" value="15,593"/>	<input type="text" value="%"/>	▼
Outlet air flow	<input type="text" value="2593,416"/>	<input type="text" value="m³/h"/>	▼
Width	<input type="text" value="1120"/>	<input type="text" value="mm"/>	▼
Height	<input type="text" value="2400"/>	<input type="text" value="mm"/>	▼
Length	<input type="text" value="1875"/>	<input type="text" value="mm"/>	▼
Mass	<input type="text" value="1850"/>	<input type="text" value="kg"/>	▼



Alternative filter elements

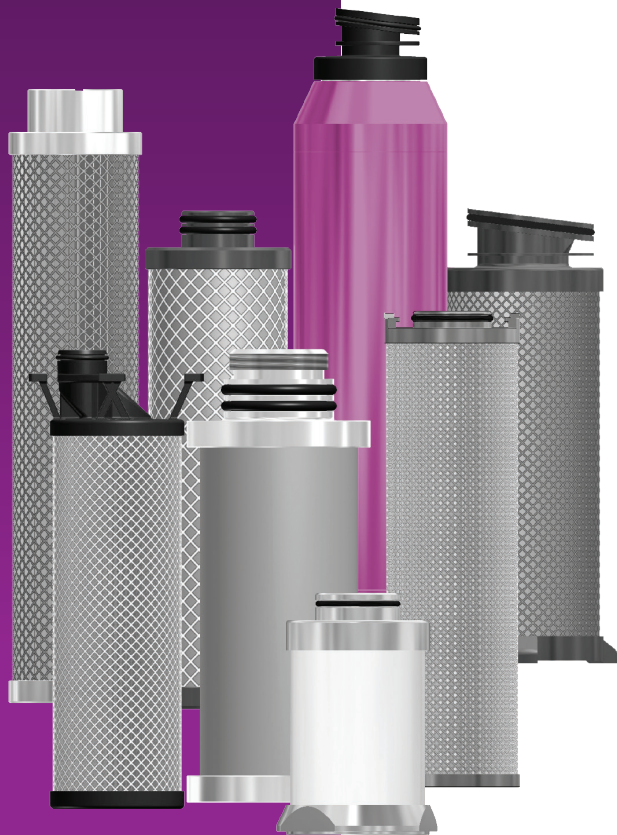

IUTA

Filter elements are designed to meet the requirements of standard ISO8573-1. Validation and testing is done in an independent institute IUTA in Germany

ABAC (new)
plastic end caps

ABAC (old)
plastic end caps

AGRE (new)
plastic end caps

AGRE (old)
plastic end caps

AIRFILTER ENGINEERING D
plastic end caps

AIRFILTER ENGINEERING
plastic end caps

AIRFILTER ENGINEERING
aluminium end caps

ALMIG
plastic end caps

ALUP (new)
plastic end caps

ALUP (previous)
plastic end caps

ALUP (old)
plastic end caps

ATLAS COPCO +
plastic end caps

ATLAS COPCO
plastic end caps

ATLAS COPCO
aluminium end caps

ATLAS COPCO (old)
plastic end caps

ATLAS COPCO (old)
aluminium end caps

ATS
plastic end caps

BALMA
plastic end caps

BEA ARS
aluminium end caps

BEA ARV
aluminium end caps

BEA BST
aluminium end caps

BEKO
plastic end caps

BOGE HP
plastic end caps

BOGE
plastic end caps

CECCATO (new)
plastic end caps

CECCATO (old)
plastic end caps

CHICHAGO PNEUMATIC (new)
plastic end caps

CHICHAGO PNEUMATIC (old)
plastic end caps

COMPAIR
plastic end caps

COMPAIR (previous)
plastic end caps

COMPAIR (previous)
aluminium end caps

DELTECH 300
plastic end caps

DELTECH
aluminium end caps

DOMNICK HUNTER OIL-X EVOLUTION
plastic end caps

DOMNICK HUNTER OIL-X PLUS
plastic end caps

DOMNICK HUNTER OIL-X PLUS
aluminium end caps

ALTERNATIVE FILTER ELEMENTS

DOMNICK HUNTER HT

aluminium end caps

DOMNICK HUNTER NH3

aluminium end caps

DONALDSON DF

plastic end caps

DONALDSON 90' series

plastic end caps

DONALDSON 90' series

aluminium end caps

DONALDSON 80' series

aluminium end caps

Alt. silicone and grease free filt. elem.

DONALDSON

silicone and grease free plastic end cap

DONALDSON

silicone and grease free aluminium end cap

Alt. sterile/vent filter elements

DONALDSON

stainless steel end caps 1.4301 (304)

Alternative process filter elements

DONALDSON

stainless steel end caps 1.4301 (304)

EKOMAK

plastic end caps

EKOMAK

aluminium end caps

FIAC

plastic end caps

FINITE J

aluminium end caps

FINITE (old)

aluminium end caps

FUSHENG (new)

plastic end caps

FUSHENG (old)

plastic end caps

FUSHENG (old)

aluminium end caps

HANKISON NGF

plastic end caps

HANKISON

plastic end caps

HANKISON

aluminium end caps

HIROSS (new)

plastic end caps

HIROSS (new)

aluminium end caps

HIROSS (old)

plastic end caps

HIROSS (old)

aluminium end caps

HITACHI

aluminium end caps

INGERSOLL RAND

plastic end caps

INGERSOLL RAND F

plastic end caps

INGERSOLL RAND FA

plastic end caps

KAESER (old)

aluminium end caps

KAESER HP

aluminium end caps

KNOCKS

aluminium end caps

KOBELCO

plastic end caps

KSI

plastic end caps

MARK (new)

plastic end caps

MARK (old)

plastic end caps

MATTEI OMAT

plastic end caps

MAUGUIERE (new)

plastic end caps

MAUGUIERE (old)

plastic end caps

MIKROPOR G

aluminium end caps

MIKROPOR GO

aluminium end caps

OMI ALPS

plastic end caps

OMI (old)

plastic end caps

ORION (new)

plastic end caps

ORION (new)

aluminium end caps

PNEUMATECH (new)

plastic end caps

PNEUMATECH (old)

plastic end caps

PREVOST MICRO

plastic end caps

PREVOST

aluminium end caps

PUSKA (new)

plastic end caps

PUSKA (old)

plastic end caps

SCHNEIDER

plastic end caps

SMC

plastic end caps

SMC

aluminium end caps

SPX NGF

plastic end caps

SULLAIR

plastic end caps

WALKER OWA ALFA

plastic end caps

WALKER OWA 20HP & 50HP

aluminium end caps

WALKER

aluminium end caps

WALKER HP

aluminium end caps

WORTHINGTON CREYSSENSAC (new)

plastic end caps

WORTHINGTON CREYSSENSAC (old)

plastic end caps

ZANDER GL

aluminium end caps

ZANDER

plastic end caps

ZANDER

aluminium end caps

Alternative sterile/vent filter elements

ZANDER

stainless steel end caps 1.4301 (304)

Alternative process filter elements

ZANDER

stainless steel end caps 1.4301 (304)

ZONDER

plastic end caps

...and many more...

ALTERNATIVE FILTER HOUSINGS

DONALDSON

DOMNICK HUNTER

ALTERNATIVE FILTER HOUSINGS

JORC

(Boge)

BEKO

(Atlas Copco, Kaeser, Ecoair, Schneider, Quincy)

WORTMANN

(Zander, Kaeser, Hankinson, Schneider, Motivair)

DOMNICK HUNTER

(Airtek, Hiross, Zander, Hiross, Compair, Ingersoll Rand)

DONALDSON

(Almig, Gardner Denver, Quincy, Aircel, Kaeser, Finite, Boge, Ultrafilter)

KAESER

ATLAS COPCO

(Alup, Abac)

OMI

(Devair)

ALTERNATIVE DESSICANT DRYERS CARTRIDGES

DONALDSON

Ultrapac 2000

ALTERNATIVE DRYER SERVICE KIT

HANKISON

OMEGA AIR

more than air



OMEGA AIR d.o.o. Ljubljana
Cesta Dolomitskega odreda 10
SI-1000 Ljubljana, Slovenia
00 386 1 200 68 00
info@omega-air.si
www.omega-air.si

950502 - 08/06/2023

